



HATCH

Manual

PRODUCT DESCRIPTION	4
1.1 Type designation	4
1.2 Intended use	4
1.3 Structure	6
1.4 General description	8
1.5 Functional description	9
1.6 Size range	9
GENERAL SAFETY REGULATIONS	10
2.1 Operating regulations	10
2.2 Explanation of safety signs	10
2.3 Basic safety measures	11
2.4 Dangerous operation	11
2.5 Occupational health and safety regulations	11
INSTALLATION REQUIREMENTS	12
3.1 HATCH fan mounting	12
3.2 Inlet and discharge side connections	12
3.3 Electric power supply	12
3.4 Ventilation system connected to fan	12
TRANSPORTATION AND STORAGE	13
4.1 Transportation	13
4.2 Storage	14
ASSEMBLING	15
5.1 Connecting axial fans	16
5.2 Wiring diagrams	17
5.3 Connecting the HATCH connection box	20
COMISSIONING	21
6.1 Check before the first start	21
6.2 Starting the ventilator for the first time	22
OPERATION	23
7.1 Electrical operating conditions	23
7.2 Application of a frequency converter	24
7.3 HATCH fan operation	24

TROUBLESHOOTING **25**

- 8.1 Possible disturbances and solutions occurring during the movement of a thermally insulated cover 25
- 8.2 Possible disturbances and solutions in axial fan operation 26

MAINTENANCE **27**

- 9.1 Screw connections 28
- 9.2 Electric motor maintenance 28
- 9.3 Maintenance of linear actuators 29
- 9.4 Comissioning 29

PRODUCT DESCRIPTION

1.1 Type designation

HATCH D1000

- HATCH - Thermally insulated cover with motorized opening roof
- D1000 - Fan nominal size

1.2 Intended use

HATCH fans are intended for use in modern ventilation and air conditioning systems and for safe fire emergency ventilation from the room through the roof, or for normal ventilation or gravity ventilation. Depending on the design of the system, the equipment can be free inlet, but it can also be installed with a inlet cone with a protective mesh or with air duct connection.

A heat-resistant, smoke-extracting axial fan is installed in the heat-insulated casing. The manufacturer selects the equipment according to its function, taking into account the applicable regulations of the European Union on energy consumption (ErP directives). These are recorded on the data sheet issued for the equipment and, in the case of an order, on the data plate on the equipment. The equipment may only be operated according to the conditions specified on the data plate.

The HATCH fans can operate in smoke extraction mode at the specified temperature and duration:

F class	Temperature [°C]	Period [minute]
F200	200	120
F300	300	60
F400	400	120
Not classified	300	120

If the fan was operating in smoke extraction mode, its service life has expired, regardless of the duration of operation, and it must be replaced!

The HATCH fans - under ambient temperature (from -20 °C to +50 °C) - are also suitable for continuous operation. In this operating state, however, it is necessary to ensure adequate protection of the fan motor (against phase loss and overcurrent, as well as overheating). The fans were tested and approved for normal and smoke extraction mode.

The regulations of the applying countries provide for the possibility of continuous operation with the emergency function (smoke extraction), which may differ, therefore the regulations of the applying country are the guiding principles, as well as the local regulations. The product manuals, descriptions, and datasheets issued for the fans contain the basic condition.

Terms of Use:

Environmental limitations:

- Function: Heat-resistant design F400 (+400°C/120 minutes); F300 (+300°C/60 minutes); F200 (+200°C/120 minutes); Not classified (+300°C/120 minutes)
- Pressure: The atmospheric pressure at all times
- Relative humidity: max. 95%
- It can be used for application based on the provisions of the regionally valid fire protection regulations, under the conditions described in the equipment certificate.

They are suitable for transporting the following media:

- clean air; max. 1.2 kg/m³; max. 95% moisture content
- The fan must not be used to ventilate air spaces classified in zones Z0, Z1, Z2, Z20, Z21, Z22, or to transport such classified media!
- Media with temperatures between -20 +50 °C, equipped with F400 ISO H, F300 ISO H, F200 ISO F motor
- In heat and smoke extraction function, for gases with a temperature corresponding to the class, in that for a specified period.

Installation conditions:

- A horizontal, flat surface is required for fixing the fan equipped with HATCH.
- In order to be able to install the fan, the device can also be made in a split design (equipped with a base element)
- A sealing strip must be placed between the lower and upper parts of the equipment
- During assembly, the retaining screws of the HATCH base plate must be sealed
- The part under the roof can be connected to an air duct with the available accessories.

1.3 Structure

The main parts of the HATCH fan are as follows:

- 1) Fixing element (base element)
- 2) Base plate
- 3) FAN connection box
- 4) HATCH connection box
- 5) Rain hood
- 6) Thermally insulated cover (upper unit)
- 7) Lifting lug
- 8) Smoke extraction fan
- 9) Actuators
- 10) Opening flap
- 11) Limit switches

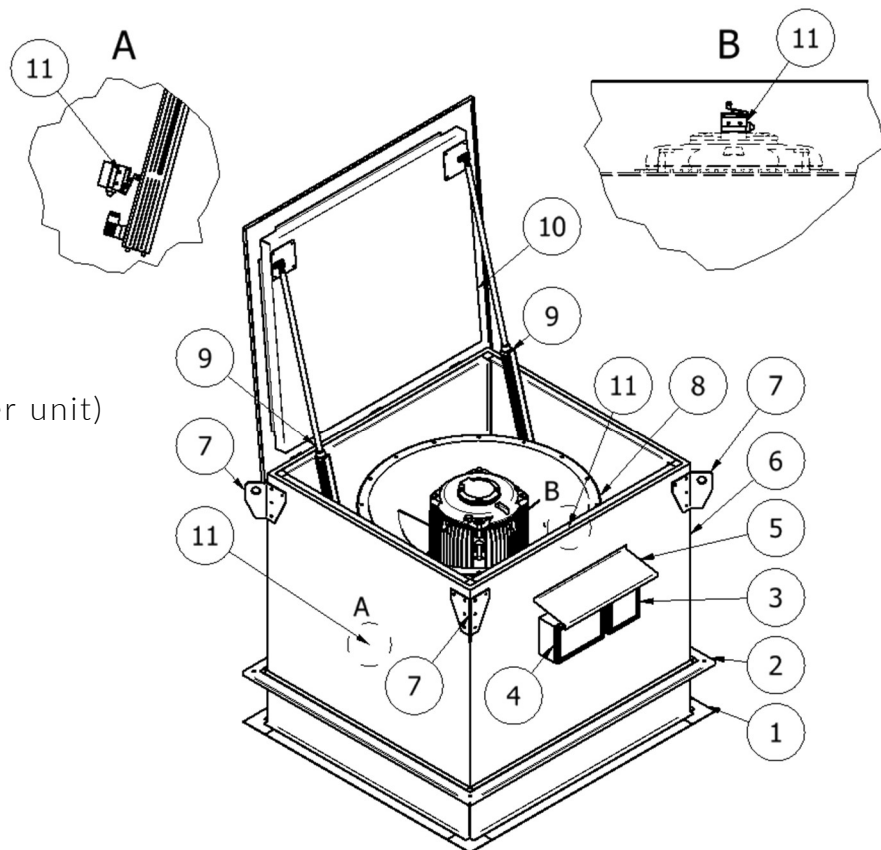





Accessories:

The HATCH fan can be ordered in 4 equipment levels, in which a transformer unit and a limit switch can be selected as accessories:

- Basic version - without transformer unit and limit switches
- Advanced version I. - Equipped with limit switch
- Advanced version II. - Equipped with a transformer unit
- Advanced version III. - Equipped with transformer unit and limit switch

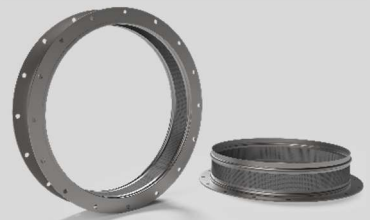
Mandatory optional accessories:

In order to protect the equipment's impeller from contact, protection against penetration must be ensured on the inlet side of the fan. The appropriate protection must be created by choosing one of the following accessories (air duct connection or protection mesh):

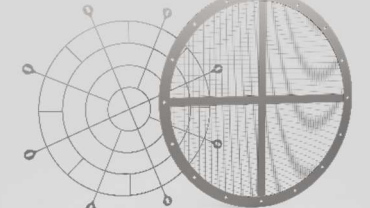
	Flexible Canvas
	Case-extension
	Flanged connector
	Inlet cone combine with protection mesh
	Protection mesh

1.4 General description

The HATCH fan is a massively constructed, split design device. The steel elements of the heat-insulated cover are made of galvanized sheet.

60 mm thick mineral wool thermal insulation takes place between the outer and inner sheet covering of the HATCH. The cover is fixed to the base plate by spot welding, on which a circular cut-out corresponding to the diameter of the fan and a standard dividing circle have been designed. The axial fan can be attached to the base plate with a rivet nut and a hex head screw, so that the fixing screws can be removed from the fan side. In the case of a device with an accessory, the attachment of the accessory is also removed by loosening the connections of the distributor circuit! The accessory must be secured against falling!

Fixing holes have been made in the corners of the base plate, with the help of which the upper and lower parts of the equipment can be easily separated. The lower unit is fixed directly to the roof structure, the upper unit can be easily removed and installed by loosening the fixing screws without breaking the roof insulation.

The connection boxes are located on the outside of the cover. In one box, only the electric power supply of the fan motor is led out (fan connection box), in the other box the power supply of the actuators, the optional limit switches and sensors are connected (HATCH connection box).

To protect the junction boxes from precipitation, a rain-dispersing plate is placed on the outer casing.

The 24 V linear actuators responsible for opening the roof are located on the inner side panels of the cover. All sizes are equipped with two actuators, which together ensure the opening speed included in the standard, and are able to fulfill SL-1000 class loads.

There are lifting lugs on the corners of the outer casing, which are responsible for the safe lifting of the equipment. Lifting of the equipment is permitted by using them, only.

The axial fan that ensures air transport takes place inside the structure. The equipment has a smoke extraction design, which, depending on the design, is suitable for one-way or reversible air delivery. When using a reversible fan the reverse air delivery mode (inflow) can only be used for normal ventilation.

ATTENTION! Hungaro-Ventilátor Kft. reserves the right to make technical changes!



1.5 Functional description

In emergency mode, the actuators are started simultaneously with the fan. The axial fan with a vertical axis draws air from the intake side through the rotating impeller, which it transports in the direction of the axis through the trailing vane, through the engine to the exhaust side. The engine is in the air stream that cools it.

The equipment can also be used for normal ventilation. In the case of a reversible axial fan, the HATCH fan can also be suitable for air replacement in normal operation. In this case, the top of the HATCH must be fully opened before starting the fan!

1.6 Size range

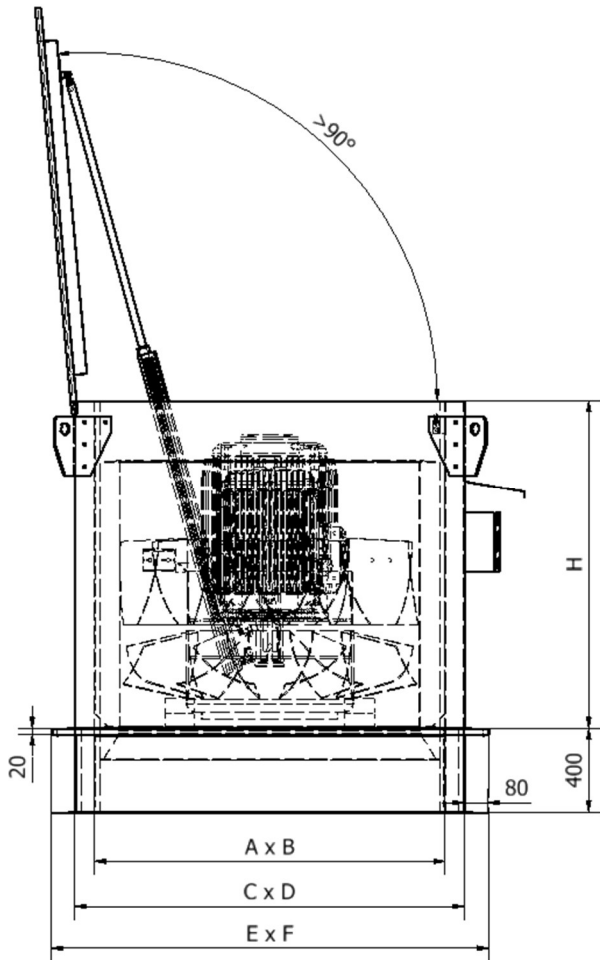

Type	A (mm)	B (mm)	C (mm)	D (mm)	E (mm)	F (mm)	H (mm)
HATCH-D315	700	847	829	974	989	1136	705
HATCH-D355	700	847	829	974	989	1136	705
HATCH-D400	700	847	829	974	989	1136	705
HATCH-D450	700	847	829	974	989	1136	705
HATCH-D500	700	847	829	974	989	1136	705
HATCH-D560	700	847	829	974	989	1136	705
HATCH-D630	967	1084	1096	1211	1256	1373	860
HATCH-D710	967	1084	1096	1211	1256	1373	860
HATCH-D800	967	1084	1096	1211	1256	1373	860
HATCH-D900	1174	1291	1303	1418	1463	1580	1100
HATCH-D1000	1174	1291	1303	1418	1463	1580	1100
HATCH-D1120	1363	1414	1492	1541	1652	1703	1125
HATCH-D1250	1513	1556	1642	1683	1802	1845	1220

GENERAL SAFETY REGULATIONS

2.1 Operating regulations

The HATCH fans are manufactured in accordance with the requirements of today's technical standards, thanks to which the fans guarantee a high degree of operational safety. However, this operational safety can only be achieved in operational practice by following the instructions in the operating instructions. Plan and carry out the installation, operation and maintenance of the devices taking these regulations into account.

It is especially important that:

- The HATCH fans should only be installed in accordance with the regulations (see the product description chapter).
- The HATCH fans should only be operated in perfect, functional condition, and the safety devices should be regularly checked for their functionality.
- The operating instructions must be permanently available in a legible state in their entirety at the place of operation of the fan.
- Only properly trained and authorized personnel may operate and maintain the machines.
- The operating personnel must be familiar with the operating instructions - and the safety regulations contained therein.
- All safety and warning instructions on the fans must be clearly visible and legible.

2.2 Explanation of safety signs



Warning

Risk of injury to life and health.



Danger to life

Danger of electric shock. Ignoring this instruction can have serious - even fatal - consequences.



Advices

User suggestions, useful advice. Ignoring them can cause significant material and personal damage, or the desired technical parameters cannot be achieved.

2.3 Basic safety measures

The HATCH Fans manufactured by Hungaro-Ventilátor Kft. are made according to high technical requirements. Numerous material, functional and quality tests guarantee the correct operation and long service life of the devices. Nevertheless, the operation of the machines can be dangerous if they are not used by qualified and competent people.



- HATCH fans may only be operated when installed and properly secured.



- Installation, electrical connection, and maintenance may only be carried out by qualified personnel.
- Operate the HATCH fan only according to the regulations, within the specified power limits (see type plate) and with a permitted medium.

2.4 Dangerous operation

Due to the rotating impeller and the high air speed, the following must be observed:

- Do not hold the rotating impeller; do not attempt to apply the brakes manually during maintenance work.
- In the case of open inlet operation, the operating personnel should always wear closed clothing, because the high air flow can suck in loose clothing and light items of clothing.
- Any larger objects (tools, etc.) that get into the fan can brake or destroy the impeller, so a protective grid, an intake fitting with a protective grid, or a closed air duct must be attached to the inlet side of the axial fan.

Due to the moving parts, the following must be observed:



- Do not hold the roof of the device in motion, do not try to brake it by hand during maintenance work.
- Any larger objects (tools, etc.) that get inside the HATCH can brake or damage the equipment. In order to avoid damage, foreign objects must be prevented from entering the equipment

2.5 Occupational health and safety regulations

When moving, installing, operating, and maintaining the fans and their accessories, the general and special occupational safety regulations must be strictly observed, especially when working at heights! (For example: working on the roof)

INSTALLATION REQUIREMENTS

3.1 HATCH fan mounting

The HATCH fan can only be installed outside of the fire section, on the roof structure of the building, with a vertical fan shaft. The equipment can be made in divided or undivided versions. In the case of a split design, the lower unit (base element) is attached directly to the roof structure, thus ensuring a stable, uniform flat connection surface for the upper unit. The upper unit is fixed using the holes in the corners of the base plate. By loosening them, the upper unit can be easily removed and installed.

3.2 Inlet and discharge side connections

The inlet side of the HATCH fan is equipped with an air duct connection or, in the case of free inlet-operation, with a protective grid or a inlet nozzle equipped with a protective grid. In any case, the pressure side of the equipment opens directly to the outside, for the protection of which the use of a protective grid is mandatory!

3.3 Electric power supply

All electrical components of the HATCH are connected to connection boxes located on the outer casing of the device. One of the switch boxes houses only the electric power supply for the axial fan. The motor side of the terminal strip placed in the connection box is already connected at the manufacturer's site. The terminals of the linear actuators that move the top of the equipment are located in the other switch box, as well as the cables of the optionally available limit switches and sensors.

The wiring of the subassemblies exposed to high temperatures was designed using a cable with adequate heat resistance. The electrical wiring diagrams of the equipment are included in chapter 5.

3.4 Ventilation system connected to fan

When the fan is installed, the air flow measured during commissioning must be within the operating range defined by the fan's characteristic curve. If it falls outside this, there is a possibility of the equipment being destroyed, and this fact in itself leads to loss of warranty.

The fan motor has been selected to transport media with a density of 1.2 kg/m³!

TRANSPORTATION AND STORAGE

4.1 Transportation

The HATCH fans are delivered fixed on individual pallets.

The following must be observed during transport:

- use suitable equipment (hoist, forklift, crane) for transport, only.
- in the case of manual transport, take into account the human lifting and holding power.

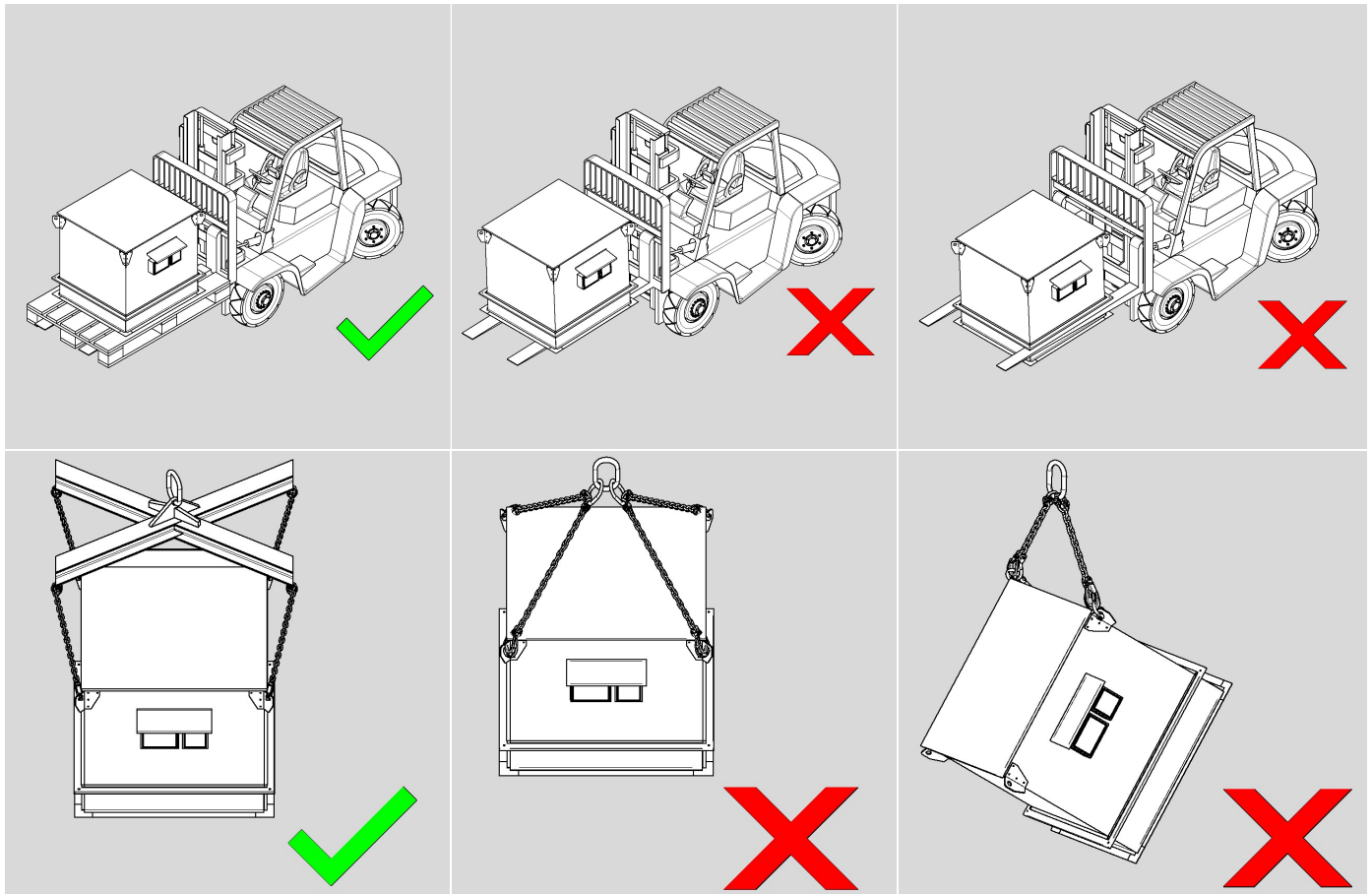

The following hazards must be considered when transporting machines:



- The transport packaging does not prevent damage caused by improper transport. The machines must not be tipped or thrown.
- Protruding, sharp edges and corners can cause injury.
- Suspended objects can fall, so do not stay under a suspended load!
- It is forbidden to stack HATCH fans on top of each other!
- The highly flammable packaging material is a fire hazard, so the use of open flames and smoking are prohibited!
- When working on the roof, the occupational safety rules for working at height must be strictly observed!

4.2 Storage

- The HATCH fan must be stored in a dry, covered place, protected from the elements.
- The HATCH fan must be protected from extreme temperatures!

An excessively long storage time (max. 1 year is recommended) causes a rapid decrease in the service life of the equipment. In such a case, an inspection of the equipment is required before installation. During the inspection, special attention must be paid to the following points:

- Proper operation of the electric motor bearing of the axial fan
- Checking the insulation resistance between windings and phases and the fan body. The insulation resistance is adequate if the measured value is greater than $1\text{M}\Omega$ when measured with a DC voltage of 500V, in a cold state (MSZ EN 60204-1: 1995). If the measured value is less than $1\text{M}\Omega$, the fan must be dried and the manufacturer must be informed immediately.
- Checking the condition of opening-closing actuators. Before installation, you must make sure that the actuators can be moved freely. During the inspection, special attention must be paid to the simultaneous movement of the engines. A lag in the movement of one of the pair of actuators can lead to deformation and destruction of the structure!
- Checking the intended free movement of limit switches. If a limit switch jammed in the end position can result in improper operation of the equipment.

ASSEMBLING



Electrical and mechanical installation work may only be carried out by a qualified specialist, considering the standards and local regulations in force at all times.

Installation, repair, and maintenance are permitted only after the fan has been completely disconnected from the electrical network.



The following must be observed when installing the HATCH fan:

- Proper fixing of the fan. The tension of the equipment can lead to improper operation, damage or destruction of the structure. If you experience tension during installation, make sure to create a flat, even surface for fixing.
- • The moving actuators require a 24 V electrical supply. In the case of a version without a transformer unit, the appropriate transformer must be provided at the installation site



Warning: The wiring of the electrical equipment must be carried out primarily according to the data plate of the electrical motor of the equipment, and secondarily based on the wiring diagrams supplied by the manufacturer, as well as the relevant regulations. You can find the circuit diagrams on the next page!

Measure the insulation resistance of the electrical part according to the chapter under "4.2 Storage".

The circuit diagram of the HATCH connection box is included in chapter 5.2.

- Due to the smoke extraction function, electric motors have PTC. However, in the case of dual-function equipment, **the fan must be equipped with external motor protection for normal operation, which is also a condition of the warranty.** However, with such an installation method, if the fan operates in smoke extraction mode, these protections must be disabled! If the connection of the motor deviates from this function, the legal consequences of the resulting damages will be transferred to the operator, and neither the manufacturer nor the distributor will be charged from now on.

In case of any problem, please contact our company. Hungaro-Ventilátor Kft. assumes no responsibility for damages resulting from faulty wiring. Such a defect is not covered by the warranty.



Checking the direction of rotation is mandatory, before which you should consider the following:

- Foreign objects must be removed from inside the fan.
- Objects that do not belong in the electrical connection box must be removed and the inner surface must be kept clean.
- It is necessary to check that the connections of the wires are secure.
- The tightness of the junction box must be checked (tight packing glands, lid seal) in accordance with the protection classification.
- The impeller must be turned a few times by hand to check for free rotation.
- The direction of rotation must be checked with a short (impulse-like) activation according to the direction arrow on the housing.
- When connecting the motor, the supply cable must be provided with a separate glass fiber insulating tape (heat resistance grade: F-155) on the section between the gland of the terminal box and the terminal strip (with the wires exposed)!

5.1 Connecting axial fans

For the electrical connection of the fan motor ceramic terminal strips are placed in the junction box. When tightening the cable fixing nut, the load capacity of the terminal strip material must be taken into account. Tightening of the nuts is done with appropriate resistance, considering the maximum tightening torque values in the table below.

Screw size	M6	M8	M10
Maximum pulling torque (+0% / -10%)	6 Nm	15 Nm	20 Nm

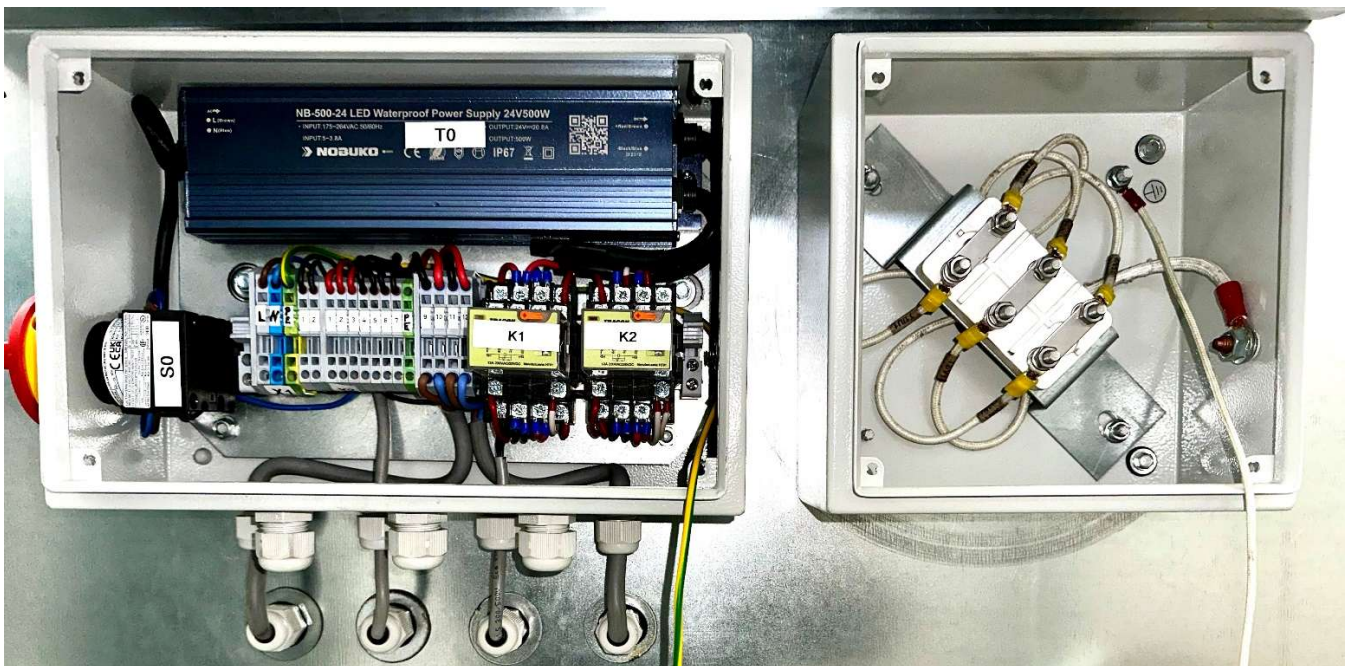

Exceeding the specified torque values can lead to breakage of the terminal strip. We are not responsible for damages resulting from improper tightening of the nuts!

ATTENTION! Adequate protection of the connection boxes against getting wet must be ensured.

5.2 Wiring diagrams

	Wiring diagram	Pole number	Electric motor type	Supply Voltage
A1		2 4 6 8 12	~400/690 V	3x400V, delta connection
A2		2 4 6 8 12	~230/400 V	3x400V, star circuit
A3		2 4 6 8 12	~230/400 V	3x400V, star circuit The star point is formed in the switch box on the motor. Only the three phases need to be connected to the connection box of the fan.

	Wiring diagram	Pole number	Electric motor type	Supply Voltage
B		2 4 6 8 12	~400/690 V	3x400V, star/delta start For star/delta (Y/D) starting, the correct timing must be included.
C		2/4 4/8 6/12	~400 V	3x400V, two-turn motor, with Dahlander coil
D		4/6 6/8 8/12	~400 V	3x400V, two-turn motor, with split winding

	Wiring diagram	Pole number	Electric motor type	Supply Voltage
E	<p>Rotating counter-clockwise</p>	2 4 6	~230 V	1x230V
	<p>Rotating clockwise</p>			

For equipment other than the above, as well as equipment equipped with special motors, ask our company for additional information.

If a heat resistant service switch is placed on the outer casing of the equipment, the fan connection box can be omitted.



5.3 Connecting the HATCH connection box

The HATCH ventilator can be ordered with 4 equipment levels:

- Basic design - without transformer unit and limit switches
- Advanced version I. - Equipped with a limit switch
- Advanced version II. - Equipped with a transformer unit
- Advanced version III. - Equipped with transformer unit and limit switch

More details can be found in chapter 7.3.

The HATCH connection box is designed according to the equipment level of the equipment according to the figure below:

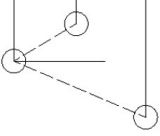
L	N	PE	1	2	1	2	3	4	5	6	7	PE	9	10	11	12
					COM	CLOSING	OPENING									
230V 50Hz 3.8A			SERVICE SWITCH INDICATOR		 1-0-2 SWITCH			HATCH IS OPEN		HATCH IS CLOSED			MOTOR 1		MOTOR 2	

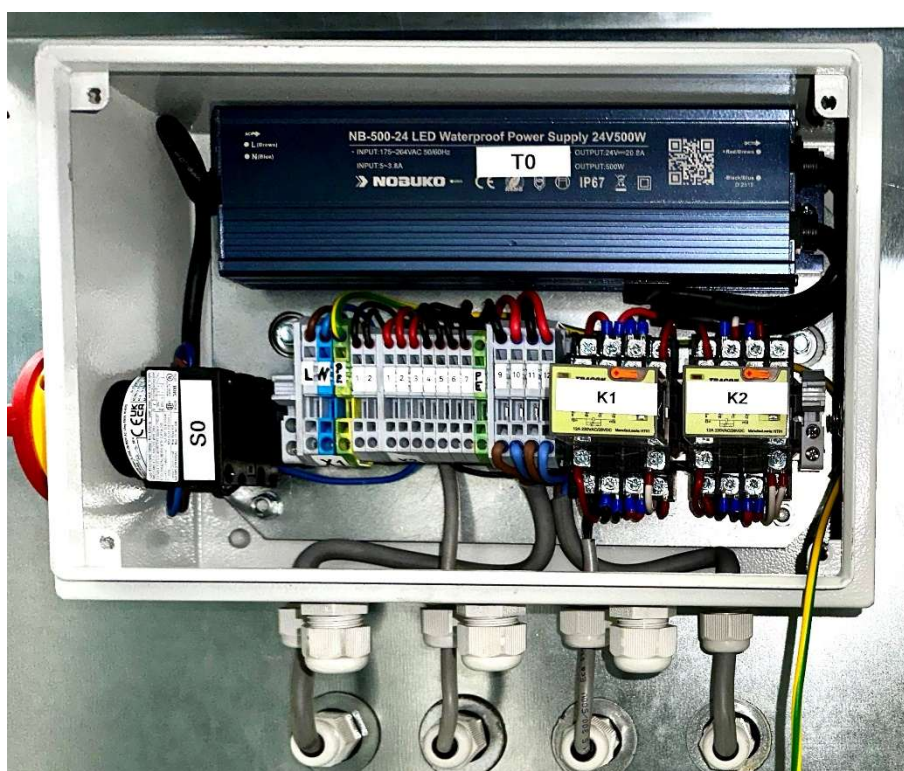

COMISSIONING

To avoid damage to the machine and life-threatening injuries during commissioning, the following points must be observed:

- Commissioning of the machine - in compliance with safety regulations - may only be carried out by qualified personnel.
- Before starting, check that all tools and foreign objects have been removed from the machine.
- Before installation, activate all safety devices and emergency switches.
- Before installation, check the direction of rotation of the motor.
- Read the 'general safety regulation'. chapter. (2.0 points)
- The existence of the commissioning protocol is a condition of the guarantee.

6.1 Check before the first start

When installing the HATCH fan, proceed in the following order:



- Check for proper installation!
- Remove foreign objects from the inlet and discharge side.
- Check that the electrical connection has been made in accordance with the factory wiring diagram and local electrical regulations.
- Is the mains voltage the same as the voltage on the machine's nameplate?
- Is the switch used suitable for the motor in terms of switching functions, switching conditions, and switching performance?
- Is the motor protection set correctly for the rated current of the motor? The adjustment must be made according to the corresponding values of the motor data plate. **Motor protection is allowed only in the case of dual-function applications, in normal operating mode, or required! It cannot be used in the smoke extraction function, it cannot stop the operation of the fan!**
- Is the motor connected correctly according to the wiring diagram? The connection of the motor must basically be carried out based on the motor data plate or based on the circuit diagram attached/sent by the manufacturer.

6.2 Starting the ventilator for the first time

Only put the fan into operation if it has been installed in accordance with the specifications!

Warning: Before starting the axial fan for the first time, it is necessary to make sure that the actuators that move the top of the device are in good condition and that they can move freely. In case of improperly functioning actuators, it is forbidden to operate the equipment!

Check for correct operation (smooth opening and closing of the roof; vibration; unbalance; current consumption; etc.).



If the fan is not operating at the correct (designed) working point (the air delivery is low or the current consumption measured per phase is higher than that stated on the data plate), then ask for the help of a specialist company or the manufacturer. In order to prevent overloading and motor burnout, measure the current consumption, the value of which must not exceed the nominal/maximum current specified on the fan's data plate. If the current consumption of the motor is higher than the value given on the data plate, the overload protection must switch off the motor. This can only be used if a dual-function fan is installed and can only work in normal mode!! **No engine protection can work in emergency mode!!!**

After the first start-up, check the mechanical connections, **especially the fan screws.**

OPERATION

During the operation of the machine, to prevent life-threatening injury to the operator and damage to the machine, the following safety advice must be observed.

Cleaning and maintenance work - in strict compliance with the operating instructions - may only be carried out by qualified personnel.

- Repair work may also only be carried out by specialist personnel - in compliance with accident prevention regulations.
- Before carrying out cleaning, repair, maintenance and other installation work, the fan must be completely disconnected from the electrical network, with a reconnection prohibition (padlock, lock, etc.) at the same time.
- Secure the area before starting operational work.
- The specified sequence of work must be followed.
- Only qualified electricians may work on electrical equipment.
- The specified tightening torque of the screws must be observed.
- Read the "general safety regulations". chapter. (2.0 points)

7.1 Electrical operating conditions

- 1) In case of emergency operation, the axial fan and the moving actuators are started at the same time!
- 2) Hungaro-Ventilátor Kft.'s smoke extraction fans are certified for fire operation in accordance with the Local Fire Regulation according to the EN 12101-3 standard together with the **DANFOSS FC 102** series frequency converter. By using a frequency converter, you can save a significant amount of expensive automation elements.
- 3) The smaller STAR motor - usually under 3 kW - marked "Y" on the data sheet - **230/400 V (50 Hz)** - starts directly, i.e. **DOL (Direct On Line)** - its current can be found on the data sheet.
- 4) The DELTA motor with a higher power - usually above 3 kW, marked "D" on the data sheet - **400/690 V (50Hz)** - is usually started with star/delta (**Y/Δ**) switching in the case of a 3x400V supply voltage. In this case, the short-term current maximum is approx. the rated current of the motor. **3** times. If there is sufficient available current, direct, i.e. **DOL (Direct On Line)** starting is also possible. Its current can be found on the data sheet.
- 5) In the case of starting with a soft starter or a frequency converter, the starting current does not exceed the rated current of the motor.
- 6) **In case of fire operation, the motor protection must be disabled**, the fan cannot stop in case of overcurrent or overheating. In the case of a trial run or function test, the guarantee condition is that the motor protection is active!
- 7) In a non-fire function, the fan motor must be protected against overheating with PTC motor protection and against overcurrent with overcurrent protection. To protect the fans from overcurrent, a small circuit breaker with characteristic "**D**" or a fuse of category "**aM**" must be used! If a fuse is used, a **phase monitoring relay** must be applied to prevent phase loss. Malfunctions resulting from the lack of motor protection are not covered by the warranty.

7.2 Application of a frequency converter

If a frequency converter is used, there is a risk of resonance on the fan, which can lead to damage and destruction of the equipment. In order to operate the HATCH fan with a frequency converter safely, special attention must be paid to the following points:

- The HATCH fan must not be operated in that speed ranges where resonance occurs.
- At speeding up and slowing down, the speed of the fan should pass through the resonance ranges as quickly as possible.
- In case of an operation of various speeds, a vibration monitoring system should be used at the fan.
- The operating speed of the fan should not exceed the value given on the fan's data plate.

7.3 HATCH fan operation

Two connection boxes are placed on the outer casing of the HATCH fan unit. All terminals for the fan motor are placed in one connection box (400 V; PTC as an option). If there is no optional PTC for the electric motor, the fan connection box can be replaced with a single service switch.

The second connection box (HATCH connection box) houses the terminals of the actuators and, as optional accessories, the limit switches, and the optional transformer unit. The HATCH connection box is equipped with a service switch. The lid of the roof fan is opened by 2 24 V motors. Actuators can be operated in two ways. Either from the control room with a 24 V cable, or via a transformer equipped with a 230/24 V service switch located on the roof fan housing with a separately installed operating cable from the building engineering control center.

All cables must be routed from the connection boxes on the side of the device to the fire protection center (Brandschutz meldezentrum). The fan can be operated from here. In case of emergency operation or extraction in normal operation, the fan and the opening actuators are started simultaneously. In the case of air replacement in normal operation, the roof must be fully opened before starting the fan.

The automation in the fire protection center must be installed in such a way that the motors operating the roof open the roof at the same time as the engine is started, and it must also be possible to open and close the roof without starting the fan. The construction of the fire protection center is the task of building automation.

The roof fan can also be used for normal extraction, but in this case all protective devices necessary to protect the motor must be installed (phase loss, overload, overcurrent intake, bearing heating). Reversible axial fan can also be used for air replacement in normal operation. In this case, the fan can only be started after the roof has been fully opened!

IMPORTANT! If the fan works in the smoke extraction function, then the protective devices mentioned above must be eliminated!

TROUBLESHOOTING

When troubleshooting, pay particular attention to the following points:

- The fault can only be eliminated by a person with appropriate professional qualifications.
- First of all, the machine must be secured against unintentional restart (accidental) by turning the machine's switch or closes its switch cabinet.
- Secure the moving parts, secure the top of the equipment in the open state.
- Read the “general safety regulation” chapter. see (2.0. point)

8.1 Possible disturbances and solutions occurring during the movement of a thermally insulated cover

Failure	Cause	Troubleshooting
The roof does not open.	The actuators were wired incorrectly.	By loosening the roof hinges, the top of the cover can be removed. Check the wiring of the actuators.
	Limit switch gives wrong signal.	By loosening the roof hinges, the top of the cover can be removed. Check the condition of the limit switch, if it does not work properly, replace it.
	One or both actuators are jammed.	By loosening the roof hinges, the top of the cover can be removed. Check the movement of the actuators. Carry out the maintenance of the actuators, if necessary, replace the faulty motor.
	The structure is strained and deformed.	Check the correct installation of the equipment. Eliminate the tension arising in the structure.
	A foreign object prevents the movement of the roof.	Remove all foreign objects from the equipment.
The roof does not close properly.	The roof structure is strained and deformed.	Eliminate tension in the roof. Check the movement of the actuators. Carry out the maintenance of the actuators, if necessary, replace the faulty motor.
	A foreign object prevents the movement of the roof.	Remove all foreign objects from inside and from edge of structure.

8.2 Possible disturbances and solutions in axial fan operation

Failure	Cause	Troubleshooting
The motor or motor control switches off	The motor has overheated, the thermal contact trips.	Cool down the engine. Depending on the switch, the fan restarts itself or needs to be restarted. Check that: <ul style="list-style-type: none"> • Is the delivered medium too hot? • Are all phases equally loaded and connected? • Does the fan's operation point match the selection? • Is the impeller jammed/stuck?
	The impeller is blocked.	Turn off the fan. Remove the obstruction. In the meantime, pay attention to the safety regulations.
	The impeller is damaged and worn.	Turn off the fan. Remove the impeller and install a new one.
The fan pumps, the air flow is interrupted periodically.	The fan works in the unfavorable characteristic curve area	Reduce system resistance if possible. In case of continuous operation, the impeller of the fan will be destroyed.
Noise during fan operation	Incorrect direction of rotation	Check the direction of rotation of the impeller!
	Impeller unbalanced or damaged	Check the condition of the impeller. Clean the impeller or remove excess deposits from the surface of the impeller. If necessary, balancing, or possibly replacing the impeller is recommended.
Vibrations occurring during fan operation	The bearing of the electric motor is damaged	Check the condition of the electric motor. If necessary, it is recommended to replace the bearings.
	Impeller unbalanced or damaged	Check the condition of the impeller. Clean the impeller or remove excess deposits from the surface of the impeller. If necessary, balancing, or possibly replacing the impeller is recommended.
	Screw connections are loose	Check the connections of the equipment. If necessary, tighten the loose connections with the specified torque values (see values at 9.1)

MAINTENANCE

Professional maintenance is a condition of the warranty!

In the case of foreign countries, the regulations in force of the competent country are the guiding principles, taking into account the regulations of the local authorities as well! If the local legislation does not provide otherwise, the inspection maintenance should be carried out every six months.

To ensure correct operation of the fan and to achieve a suitable service life, the prescribed periodic inspection and planned maintenance must also cover the accessories assembled with it.

Factory Service:



Hungaro-Ventilator Kft. (Hungary-9483 Sopronkövesd, Táncsics M. u 18.)

E-mail: service@hungaro-ventilator.hu

Tel.: +36-99-536-072

Maintenance intervals:

- For normal air ventilation fans, **3 months is recommended** (depending on air pollution).
- For CO and smoke removal fans: **mandatory every 6 months**

Warning!

Please carry out the maintenance work in this guide at the specified intervals - failure to do so will void the warranty. It also voids the warranty and endangers the safety of operation if you do not use spare parts distributed by the manufacturer!

Dust, caustic and acidic vapors and gases mixed with the transported air flow have a natural abrasive and corrosive effect on the impeller and the housing and can deposit. Because of these natural wear and tear, the material can wear out to such an extent that it no longer meets expectations. Uneven deposits on the impeller can cause imbalance and thus unstable running, which in turn leads to damage to the motor bearings. Deposits on the housing lead to a reduction of the free cross-section and a roughening of the housing, which adversely affects the performance data of the fan. If the inspection, which depends on the transported medium and the different operating conditions in each case, shows even a small amount of wear, then the individual parts must be cleaned in time, in case of greater wear, immediate replacement is justified.

Before any maintenance work:

- The fan must be properly stopped and completely disconnected from the electrical network, simultaneously with a reconnection prohibition (padlock, lock, etc.).
- Wait until the impeller stop!
- Ensure non-restartability!
- Clean the fan.
- Clean the inlet opening.
- Clean the impellers (if necessary, remove the protection against penetration).



In addition to following the prescribed safety instructions, only use commercially available cleaning agents! The use of scratching or rubbing tools that damage the surface protection is prohibited!

- Protect the engine from water jets!
- The integrity of the impeller and blades must be checked!

General checks:

- Look for signs of a lubricant leak.
- Checking the integrity of surface protection (paint or zinc layer).
- Control of noises occurring during equipment operation.
- Checking the integrity of cabling.
- Checking the integrity and tightness of seals and stuffing boxes.

9.1 Screw connections

The screw connections of the equipment must be checked during the prescribed maintenance!

Important:

The screws of the fan (with the exception of the screws of the electrical connection. see: Installation) and the screws for fixing the impeller must be tightened with the torque specified in the attached tables!

Screws (strength class 8.8):

Screw	M4	M5	M6	M8	M10	M12	M14	M16	M18	M20
pulling torque (+0% / -10%)	3,4 Nm	6,5 Nm	11 Nm	28 Nm	55 Nm	95 Nm	155 Nm	230 Nm	275 Nm	385 Nm

The given values refer to galvanized screws and non-oiled screw connections!

9.2 Electric motor maintenance

Warning!

The electric motor can only be disassembled by the manufacturer, or a specialist company designated by the manufacturer!

In the event of a limited motor fault, notify the manufacturer or distributor of the fan! De-energize the fan motor at the same time as reporting the error, but do not disconnect the wiring, leave it unchanged.

By disassembling the engine, the operator assumes all legal consequences!

Checks to be performed during periodic maintenance:

- Look for signs of a lubricant leak.
- Checking noises occurring during electric motor operation.
- Checking electric motor bearings with bearing diagnostic tools.

9.3 Maintenance of linear actuators

Attention!

Prior to all installation and maintenance work, the equipment must be disconnected from the electrical network and provision must be made to prevent reconnection (padlock, lock, etc.) The top of the de-energized equipment must be secured and prop up to prevent accidents!

Checks to be performed during periodic maintenance:

- Look for signs of a lubricant leak.
- Checking the integrity of cabling
- Checking the integrity of the actuator housing and push rod.
- Dust-free check.
- Checking the proper lubrication of the push rod.
- Checking connections of connection points.
- Checking noises occurring during actuator movement.

To ensure the proper operation of the actuators, a basic requirement is to ensure that the push rods are dust-free and properly lubricated. After performing the checks, the actuators must be cleaned. If necessary, but no more than once a year, it is recommended to lubricate the rods of the actuators.

Attention! Structural disassembly of the actuators is prohibited and also voids the warranty!

If you find any error during the check, notify the manufacturer or distributor of the equipment!

Once the inspection and maintenance work has been completed, the equipment must be re-energized and manually started to make sure that the actuators are working correctly.

9.4 Commissioning

After the inspection and maintenance work is completed, the equipment must be put into operation again. The operation must be carried out paying special attention to the following points:

- Commissioning of the machine - in compliance with safety regulations - may only be carried out by qualified personnel.
- Before starting, check that all tools and foreign objects have been removed from the machine.
- Reinstall protection against intrusion
- Before installation, activate all safety devices and emergency switches.
- Before installation, check the direction of rotation of the motor.
- Read the "General safety regulations". chapter. (2.0 points)

Thank you for your attention!

We trust that the above instructions will help you in your work and that the equipment will operate as intended.