

**VHA AXIAL VENTILATOR**

## Product description

4

1.1 – Type designation	4
1.2 – Intended use	4
1.3 – Structure	6
1.4 – Optional accessories	7
1.5 – General description	9
1.6 – Functional description	9
1.7 – Size range	10

## General Safety regulations

13

2.1 – Operating regulations	14
2.2 – Expanation of safety signs	14
2.3 – Basic safety measures	15
2.4 – Dangerous operation	15
2.5 – Occupational health and safety regulations	15

## Installation requirements

16

3.1 – Ventilator mounting	17
3.2 – Suction and discharge side connections	17
3.3 – Electric power supply	17
3.4 – Ventilation system connected to fan	17
3.5 – Roof fan assembly variations – VHA+DS; +DT; +DL types	18

## Storage and transportation

20

4.1 – Transportation	21
4.2 – Storage	22
4.3 – Dimensions	22

## Assembling

23

5.1 – Common installation errors	28
5.1.1 – Inflow	28
5.1.2 – Exhaust	29
5.1.3 – Arches and elbows before and after the fan	30
5.1.4 – Cross section changes	30
5.1.5 – Flexible connections	31

## Comissioning

32

6.1 – Check before the first start	33
6.2 – Starting the ventilator for the first time	34
6.3 – Check after the first start	34

## Operation

35

## Troubleshooting

38

7.1 - Tabular overview of possible disturbances and help for troubleshooting

39

## Maintenance

40



## PRODUCT DESCRIPTION

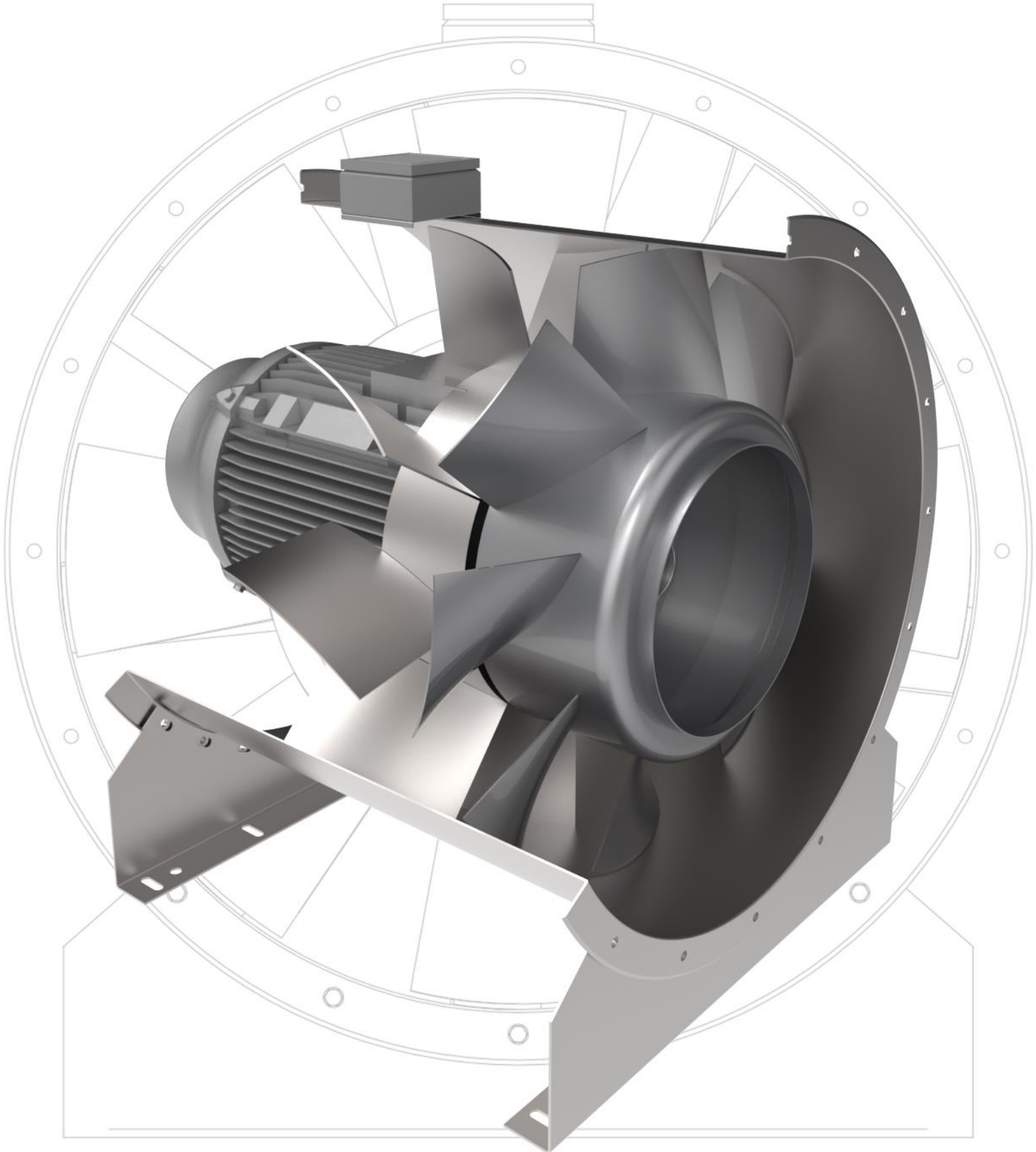



## 1.1 - Type designation

### VHA 355-8-23°-2

VHA	=	Type of Fan
355	=	Fan factory size (front diameter)
8	=	Impeller blade number
23°	=	Impeller blade angle
2	=	Pole number

## 1.2 - Intended use

The VHA axial fan and the VHAD roof fan family were developed for use in modern ventilation systems. The fan is only suitable for transporting clean air. The pressure nozzle of the VHA axial fan primarily has a pipeline - optimally a diffuser - but it is also suitable for blowing into open space. The VHAD roof fan is used for extraction from the room or for blowing in, according to the type of roof cap. Roof ventilators usually have an air duct on the side of the building, but they can also be operated outdoors with a suction and/or pressure side. In the case of a free suction or discharge side, it can only be operated with a suitable protective grid!

The manufacturer selects the equipment according to its design - axial fan or roof fan - and its function, taking into account the applicable regulations of the European Union on energy consumption (ErP directives). These are recorded on the data sheet issued for the equipment and, in the case of an order, on the data plate on the equipment. During the operation of the equipment, it can only be done according to the conditions specified on the data plate.

The fans - under normal conditions (from -20 °C to +50 °C) - are suitable for continuous operation. In addition to carrying out maintenance work, the lifetime of the fans is in principle unlimited. The fans have been inspected and approved.

## Terms of Use:

### Environmental limitations:

- clean air; max. 1.2 kg/m<sup>3</sup>; max. 95% humidity
- the fan must not be used to ventilate air spaces classified in zones Z0, Z1, Z2, Z20, Z21, Z22, or to transport such classified media!
- Mediums temperatures between -20 +50 °C,
- for CO ventilation of underground garages

**Installation conditions:**

- The fans are installed either in a pipeline or in an arrangement without a pipeline or air duct connection, and as a roof fan they are installed on a plinth element.
- They are allowed installed with a horizontal or vertical axis, using a suitable accessory.
- In the case of operation without a pipeline or air duct connection, in order to prevent access to the rotating parts, the use of a protective grid is mandatory!
- The fans are not allowed to be operated without the necessary safety devices.
- Foreign objects must be prevented from entering the device
- Adequate air inlet and outflow conditions must be ensured during installation.

**Installation conditions for VHAD type roof ventilator:**

- DS and DT type roof ventilators equipped with a roof cap can be used for both supply and exhaust.
- Roof ventilators fitted with a DL type roof cap are only suitable for extraction.
- Roof ventilators equipped with a DL type roof cap and a single-turn motor can only be operated in the range of 15-25Hz with a frequency converter, other than in an emergency. In the case of equipment equipped with a two-speed motor, its operation other than in an emergency is only allowed at the lower speed.
- Roof ventilators equipped with a non-return damper can only be used for extraction. For inlet, it is recommended to use a motorized damper instead of a non-return damper.
- The fan unit must be placed on the roof on the plinth element corresponding to the base plate.
- In the case of a built footing, the minimum snow limit in accordance with local regulations must be taken into account.
- The edge of the plinth must be horizontal and smooth, with a smooth closing edge.
- A sealing strip must be placed between the plinth and base plate.
- The clamping screws of the base plate must also be sealed.
- It is recommended to insulate the inner surface of the base plate from the inside to avoid unwanted condensation.

## 1.3 - Structure

The axial fan consists of the following main parts:

- 1) Fan housing
- 2) Guide vane
- 3) Ventilator impeller
- 4) Electric Motor
- 5) Terminal box

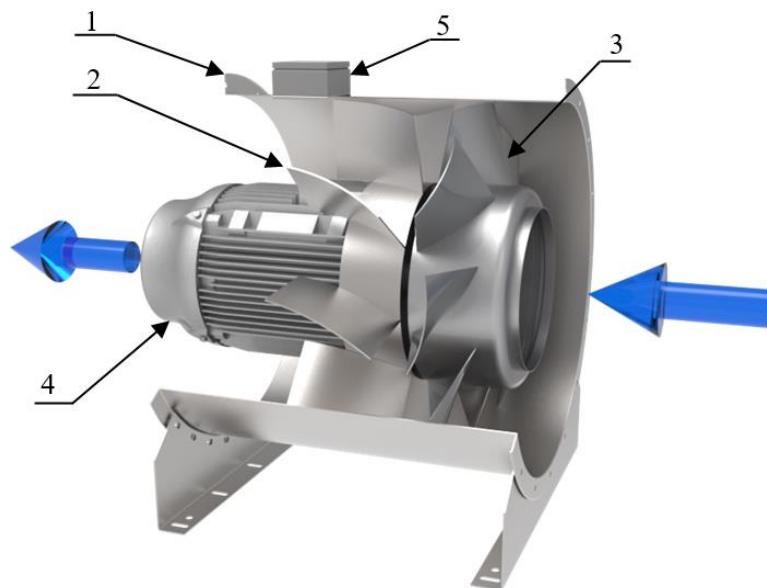

The roof fan consists of the following main parts:

- 1) Roof Cap (DS, DT, DL típusok)
- 2) Axial Fan
- 3) Base Plate

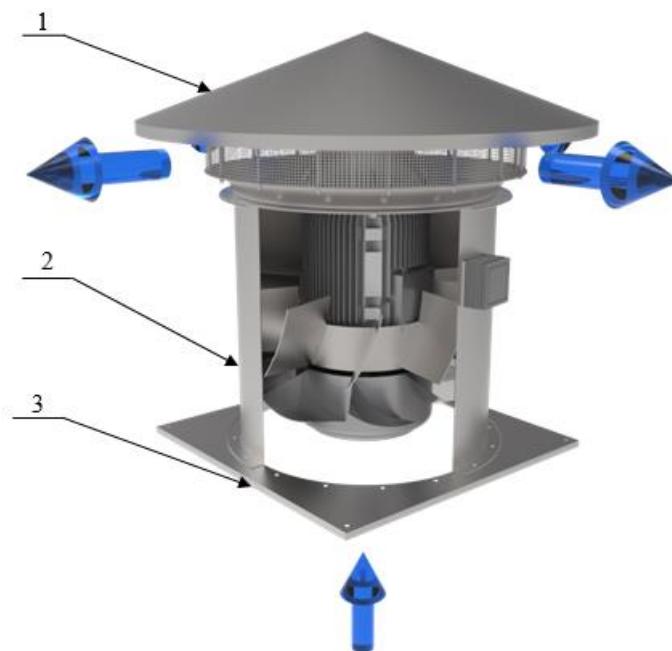

**1.4 – Optional accessories**

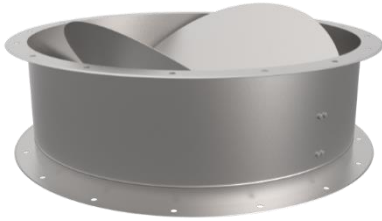

Automatic shut-off damper  
for vertical use



Automatic shut-off damper  
for horizontal use



Flexible Canvas



Protection grill



Motorized control damper  
with connection plate



Tube silencer



Diffuser



Inlet cone



45°-os intake or exhaust

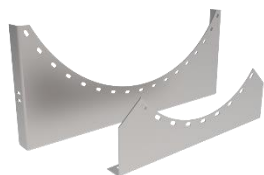

Mounting Feet

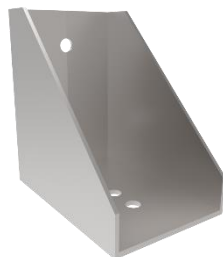

Bracket for vertical installation

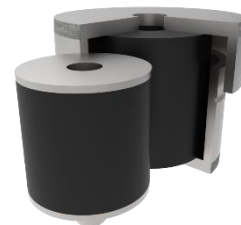

Heat-resistant vibration absorber

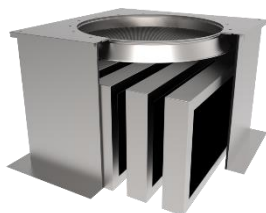

Roof silencer socket



Thermally insulated Roof socket

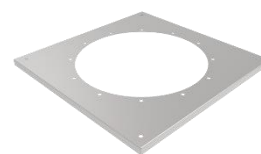

Insert Plate



Lamellar Roof Cap  
(DL – for exhaust only)

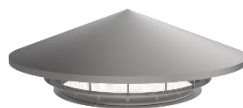

Roof Cap DS

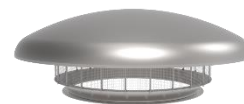

Roof Cap DT

## 1.5 – General description

The VHA fan and VHAD roof fan are solidly constructed, welded equipment. Its surface protection can be galvanized or painted.

The fan housing is a welded steel plate, which is an integral part of the rear deflector blade, which was included in the construction to optimize air transport. The central part of the rear deflector is also the engine mount. The flanges are flanged from the material of the house.

The edge of the house is equipped with a standard hole distribution, which can be used to install it in a pipeline, or in the case of horizontal installation, it can be equipped with feet. In the case of vertical installation, the device hooves are placed on the casing of the fan housing, and when used as a roof fan, the edge of the fan housing is set up on the plinth element.

The axial impeller is attached directly to the motor shaft (latch and locking screw). The impeller consists of a steel hub and steel blades welded to the hub, the angle of which is fixed and cannot be changed. The impeller is balanced both statically and dynamically. The impeller can be made with a normal or increased blade gap (gap between the impeller blade and the fan housing), which allows the fan to be set up in different places. (see under point 3.1).

The electric motor is an asynchronous, alternating current, peripheral motor with at least IP 55 protection.

The aluminum terminal box is placed outside the fan housing, in which the terminal is located. The motor and terminal are wired at the manufacturer's site.

The VHAD roof fan is made by assembling a vertical axis VHA axial fan with a base plate and a roof cap. The base plate can be ordered in several sizes according to the size of the plinth element. It is a supporting structure made of galvanized sheet, which is used to fix the VHA fan on the supporting plinth.

The VHAD roof fan can be ordered with three types of roof caps. The DS and DT types are suitable for both inhalation and exhalation, while the DL type is only for exhaust.

## 1.6 – Functional description

The VHA axial fan draws air from the intake side through the rotating impeller, which it transports in the direction of the axis through the air deflector, through the engine to the exhaust side. The engine is in the air stream that cools it.

The VHAD roof fan must be mounted on the roof of the building in a vertical axis position. It is suitable for exhaust or blow-in according to the type of roof cap and the air delivery direction of the fan.

1.7 - Size range

VHA type size range

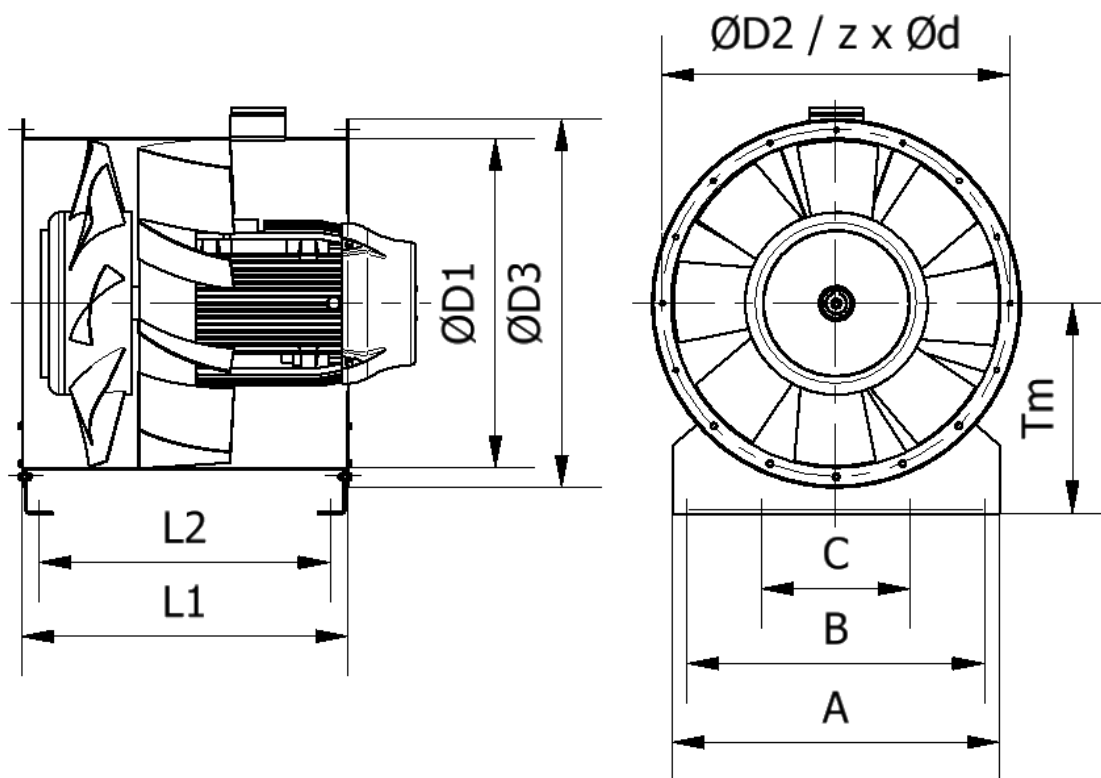

Nominal diameter (mm)	$\text{ØD1}$ (mm)	$\text{ØD2}$ (mm)	$\text{ØD3}$ (mm)	$L1$ (mm)	$L2$ (mm)	$A$ (mm)	$B$ (mm)	$C$ (mm)	$Tm$ (mm)	$\text{Ød1}$ (mm)	$z$ (db)
315	315	356	395	425	375	315	260	130	210	12	8
355	356	395	436	425	375	355	300	150	230	12	8
400	400	438	480	425	370	400	340	170	255	12	12
450	450	487	530	425	370	450	400	200	280	12	12
500	500	541	580	425	365	500	440	220	315	12	12
560	557	629	669	520	460	560	500	250	360	14	16
630	634	698	744	520	450	630	560	280	405	14	16
710	710	775	820	525	450	710	640	320	450	14	16
800	794	861	904	525	450	800	720	360	500	14	16
900	907	958	1017	900	825	900	820	410	580	14	16
1000	1001	1067	1111	900	825	865	780	390	635	14	16
1120	1114	1200	1234	895	815	1024	940	470	775	14	16
1250	1256	1337	1376	895	815	1228	1120	560	815	14	24
1400	1401	1491	1521	1040	940	1367	1260	630	894	14	24
1600	1589	1663	1709	1040	945	1550	1440	720	994	14	24
1800	1801	1856	1921	1570	1475	1725	1560	780	1094	14	24
2000	2000	2073	2120	1570	1475	2000	1840	920	1256	14	32

VHADL, VHADS, VHADT types size range

DL Roof Cap

DS Roof Cap

DT Roof Cap

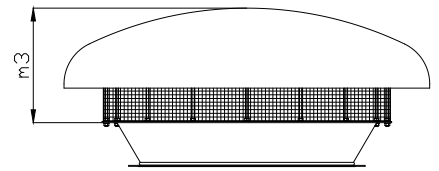
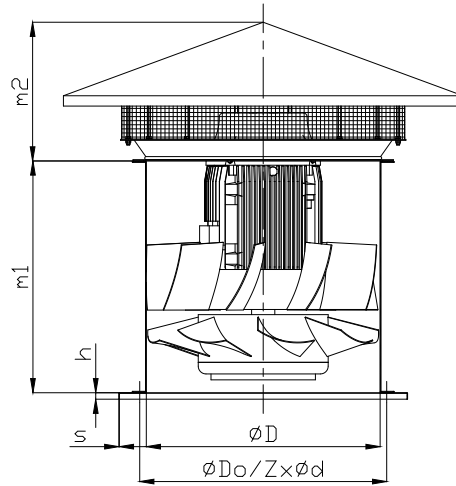
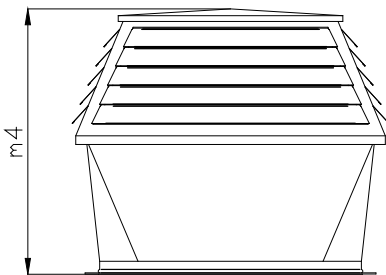

Nominal diameter	ØD	ØDo	m1	m2	m3	m4	s	h	Z x Ød
(mm)	(mm)	(mm)	(mm)	(mm)	(mm)	(mm)	(mm)	(mm)	(db x mm)
315	315	356	425	320	-	-	2	25	8 x M10
355	356	395	425	340	-	750			8 x M10
400	400	438	425	400	-	750			12 x M10
450	450	487	425	480	-	750			12 x M10
500	500	541	425	550	-	780			12 x M10
560	557	629	520	590	-	840			16 x M12
630	634	698	520	610	-	855			16 x M12
710	710	775	525	630	-	875			16 x M12
800	794	861	525	650	-	910			16 x M12
900	907	958	900	-	575	940			16 x M12
1000	1001	1067	900	-	630	985			16 x M12
1120	1114	1200	895	-	695	1150			16 x M12
1250	1256	1337	895	-	770	1470			24 x M12
1400	1401	1491	1040	-	860	1600			24 x M12

## About our Company:

The name of Hungaro-Ventilator Ltd. is now completely connected to quality and expertise.

Our company was founded in 2005, now has 50 employees and manufactures smoke extraction and emergency ventilation equipments in Sopronköves on 6.500 m<sup>2</sup> production area.

We have more, than 15 years of experience and we are one of the largest Hungarian manufacturing and exporting companies in the sector.

Beside of Hungary, the additional export destinations are in EU, and we have several partners outside the EU as well.

The equipments manufactured by the company, - with exception of electric motors, - are entirely self-developed. Year to year thousands of fans and pressure relief dampers were manufactured is our factory in Sopronkövesd.

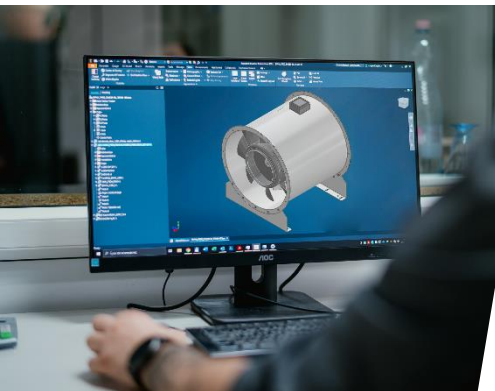



# GENERAL SAFETY REGULATIONS



## 2.1 – Operating regulations

VHA and VHAD fans are manufactured in accordance with the requirements of today's technical standards, thanks to which the fans guarantee a high degree of operational safety. However, this operational safety can only be achieved in operational practice by following the instructions in the operating instructions. Plan and carry out the installation, operation and maintenance of the devices taking these regulations into account.

### It is especially important that:

- The fans should only be installed in accordance with the regulations (see the product description chapter).
- The fans should only be operated in perfect, functional condition, and the safety devices should be regularly checked for their functionality.
- The operating instructions must be permanently available in a legible state in their entirety at the place of operation of the fan.
- Only properly trained and authorized personnel may operate and maintain the machines.
- The operating personnel must be familiar with the operating instructions - and the safety regulations contained therein.
- All safety and warning instructions on the fans must be clearly visible and legible.

## 2.2 – Expanation of safety signs



### Caution!

Risk of injury to life and health.



### Danger of life

Danger of electric shock. Ignoring this instruction can have serious - even fatal - consequences.



### Advice

User suggestions, useful advice. Ignoring them can cause significant material and personal damage, or the desired technical parameters cannot be achieved.

## 2.3 – Basic safety measures

Axial fans and roof fans manufactured by Hungaro-Ventilátor Ltd. are made according to high technical requirements. Numerous material, functional and quality tests guarantee the correct operation and long service life of the devices. Nevertheless, the operation of the machines can be dangerous if they are not used by qualified and competent people.



- The fans may only be operated when installed - connected on the air side. (with air duct connection or using a protective grid)



- Installation, electrical connection and maintenance may only be carried out by qualified personnel.
- Operate the fan only according to the regulations, within the specified power limits (see type plate) and with a permitted medium.

## 2.4 – Dangerous operation

**Due to the rotating impeller and the high air speed, the following must be observed:**

- Do not hold the rotating impeller; do not attempt to apply the brakes manually during maintenance work.
- In the case of open suction operation, the operating personnel should always wear closed clothing, because the high air flow can suck in loose clothing and light items of clothing.
- Any larger objects (tools, etc.) that get into the device can brake or destroy the impeller, therefore a protective grid is required in open suction or open-air operation.

## 2.5 - Occupational health and safety regulations

When moving, installing, operating, and maintaining the fans and their accessories, the general and special occupational safety regulations must be strictly observed, especially when working at heights! (For example: Roof fan)



# INSTALLATION REQUIREMENTS



### 3.1 – Ventilator mounting

The VHA fan can be installed with both a horizontal and vertical axis. For horizontal installation, the fan must be mounted on legs, for vertical installation, on appliance feet, or set on the edge of the fan. A vibration-damping rubber or steel spring can be used for the support points.

VHAD roof ventilators are installed on the roof and only in a vertical position. The fan structure is connected to the plinth element on the roof by fixing screws through an intermediate plate. The plinth can be built (concrete, ytong, etc.) or, in the case of factory accessories, steel.

### 3.2 – Suction and discharge side connections

If the VHA fan is installed in a pipeline, it is necessary to use a vibration damper. A silencer can be installed on both sides of the fan. In this case, the muffler is attached to the rim of the fan housing with screws. In the case of suspended installation, the silencer must also be provided with a safety attachment, which will hold the device in the event of failure of the original, intended installation, thereby preventing accidents or material damage. The safety fastening can be a fastening rope or a fastening chain, which must be fixed regardless of the original attachment points (the original attachment points must also be heat-resistant, according to the application class) and in a normal situation these safety attachments must be in a loose, unloaded state! If it is installed with a free fan side, a suction or pressure fitting must be used to increase performance. In any case, they must be provided with a protective grid.

For VHAD roof fans, a roof cap is installed on the pressure side of the vertical axis VHA axial fan.

### 3.3 – Electric power supply

The motor side of the terminal strip located in the electrical terminal box is connected. (See wiring diagram under point 5.0)

The supply cable must be properly secured and mechanically protected, and the cable must not come into contact with the fan housing. When choosing the type of cable, the installation method used and the contact protection solution, the relevant standards must be taken into account to the maximum extent (DIN 4102-12).

### 3.4 – Ventilation system connected to fan

When the fan is installed, the air flow measured during commissioning must be within the operating range defined by the fan's characteristic curve. If it falls outside this, there is a possibility of the equipment being destroyed, and this fact in itself leads to loss of warranty. **The fan motor has been selected to transport media with a density of 1.2 kg/m<sup>3</sup>!**

## 3.5 – Roof fan assembly variations – VHA+DS; +DT; +DL types

### Roof Silencer Sockets:

		
<p><b>Plinth package "A"</b></p> <p>VHA fan with conical roof cap (DS), Roof Silencer Socket with Inlet cone and automatic shut-off damper.</p>	<p><b>Plinth package "A1"</b></p> <p>VHA fan with conical roof cap (DS), Roof Silencer Socket with Inlet cone and with a circular connection base plate.</p>	<p><b>„Plinth package "C"</b></p> <p>VHA fan with conical roof cap (DS), and Roof Silencer Socket with Inlet cone.</p>



### Thermally insulated plinth elements:

			
<p><b>Plinth package "E"</b></p> <p>VHA fan with conical roof cap (DS), with thermally insulated plinth element, and with Inlet cone.</p>	<p><b>Plinth package "E2"</b></p> <p>VHA fan with conical roof cap (DS), with thermally insulated plinth element.</p>	<p><b>Plinth package "F"</b></p> <p>VHA fan with conical roof cap (DS), with thermally insulated plinth element and with automatic shut-off damper.</p>	<p><b>Plinth package "Zs"</b></p> <p>VHA fan with conical roof cap (DS), with thermally insulated plinth element és motorized damper.</p>

## Built-in plinth elements:

			
<p><b>Plinth package "G1"</b></p> <p>VHA fan with conical roof cap (DS), with built-in plinth elements and inlet cone.</p>	<p><b>Plinth package "G2"</b></p> <p>VHA fan with conical roof cap (DS), with built-in plinth elements.</p>	<p><b>Plinth package "H1"</b></p> <p>VHA fan with conical roof cap (DS), with built-in plinth elements and automatic shut-off damper.</p>	<p><b>Plinth package "H2"</b></p> <p>VHA fan with conical roof cap (DS), with built-in plinth elements, inlet cone and automatic shut-off damper.</p>

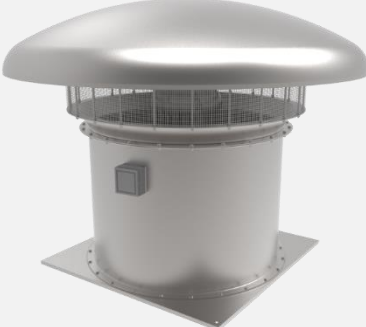
## Roof Cap types:

		
<p><b>Roof Cap types „DS"</b></p> <p>Roof cap for exhaust and supply</p>	<p><b>Roof Cap types „DT"</b></p> <p>Roof cap for exhaust and supply</p>	<p><b>Roof Cap types „DL"</b></p> <p>Lamellar Roof Cap for exhaust, only!</p>



# STORAGE AND TRANSPORTATION



## 4.1 – Transportation

The fans are delivered fixed on a pallet. VHAD roof ventilators are delivered fixed on individual pallets.

### The following must be observed during transport:

- use suitable equipment (hoist, forklift, crane) for transport, only;



- in the case of manual transport, take into account the human lifting and holding power.
- a raklapra rögzített ventilátor nem szállítható és emelhető függőleges helyzetbe fordítva



### The following hazards must be considered when transporting machines:



- The transport packaging does not prevent damage caused by improper transport. The machines must not be tipped or thrown.
- Protruding, sharp edges and corners can cause injury.
- Suspended objects can fall, so do not stay under a suspended load!



- Objects piled too high may fall!
- The highly flammable packaging material is a fire hazard, so the use of open flames and smoking are prohibited!
- When working on the roof, the occupational safety rules for working at height must be strictly observed!

### 4.2 – Storage

- The fan must be stored in a dry, covered place, protected from the elements, possibly covered with a tarp, protected from dirt.
- The fan must be protected from extreme temperatures!
- An excessively long storage time (max. 1 year is recommended) causes a rapid decrease in the service life of the equipment. Before installation, the correct operation of the motor bearings must be checked, as well as the insulation resistance between the windings and the phases and the fan body must be measured. The insulation resistance is adequate if the measured value is greater than 1MΩ when measured with a DC voltage of 500V, in a cold state (MSZ EN 60204-1: 1995). If the measured value is less than 1 MΩ, the fan must be dried, and the manufacturer must be informed immediately.

### 4.3 - Dimensions

See chapter "Size range". (1.7. point)



# ASSEMBLING

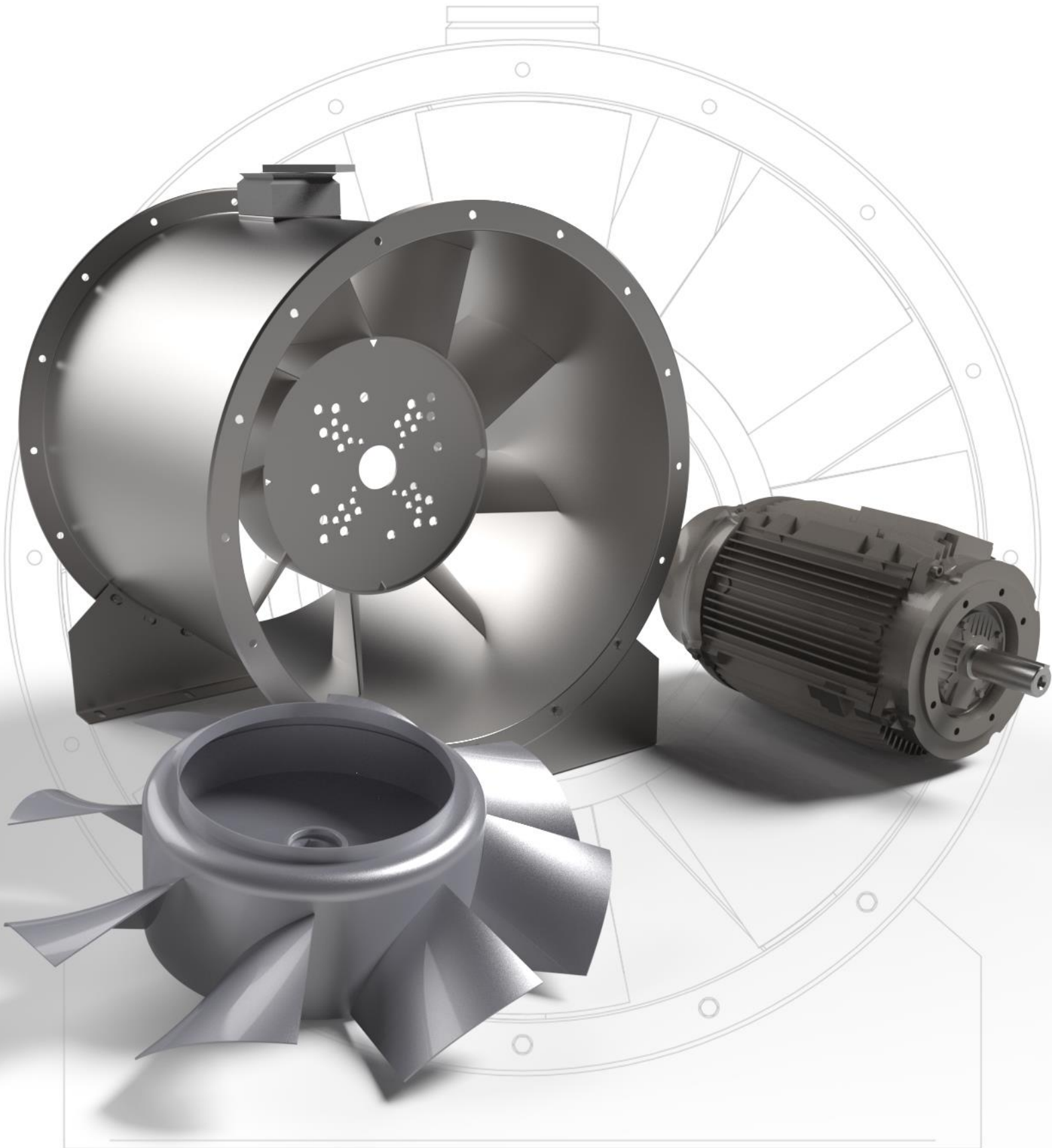



Electrical and mechanical installation work may only be carried out by a qualified specialist, taking into account the regulations in force at all times.

Installation, repair and maintenance are permitted only after the fan has been completely disconnected from the electrical network.



### The following must be observed when installing the fan:

- Proper fixing of the fan.
- The fan housing must not be strained, use compensation if necessary.
- The installation position must match the one specified in the order.
- Fügőleges helyzetű visszacsapó helyes beépítés helyzetére (csak elszívásra alkalmas, a lamellák felfelé nyíljanak).



**Caution:** The wiring of the electrical equipment must be carried out primarily according to the data plate of the electrical motor of the equipment, and secondarily based on the wiring diagrams supplied by the manufacturer, as well as the relevant regulations. You can find the circuit diagrams on the next page!

Measure the insulation resistance of the electrical part according to the chapter under "4.2 Storage.

In case of any problem, please contact our company. **Hungaro-Ventilátor Kft. assumes no responsibility for damages resulting from faulty wiring.** Such a defect is not covered by the warranty.



### Checking the direction of rotation is mandatory, before which you should consider the following:

- Foreign objects must be removed from inside the fan.
- Objects that do not belong in the electrical connection box must be removed and the inner surface must be kept clean.
- It is necessary to check that the connections of the wires are secure.
- The tightness of the junction box must be checked (tight packing glands, lid seal) in accordance with the protection classification.
- Rotating parts should be protected against contact by installing a protective grid (see accessories).
- The impeller must be turned a few times by hand to check for free rotation.
- The direction of rotation must be checked with a short (impulse-like) activation according to the direction arrow on the housing.

Wiring diagrams:

	Wiring diagram	Pole number	Motor voltage	Remarks
A1		2 4 6 8 12	~400/690 V	3x400V motor star circuit
A2		2 4 6 8 12	~230/400 V	3x400V motor
B	<p>With direct actuator</p> <p>Y With direct actuator</p>	2 4 6 8 12	~400/690 V	3x400V motor in delta connection  For star/delta (Y/D) start, appropriate timing must be included.

	Wiring diagram	Pole number	Motor voltage	Remarks
C	<p>High speed</p> <p>YY</p>	2/4 4/8 6/12	~400 V	3x400V, two-turn motor, with Dahlander coil
	<p>Low speed</p> <p>Y</p>			
D	<p>High speed</p> <p>Y</p>	4/6 6/8 8/12	~400 V	3x400V two-turn motor, split winding
	<p>Low speed</p> <p>Y</p>			
E	<p>Rotating clockwise</p> <p>Rotating clockwise</p>	2 4 6	~230 V	1x230V motor
	<p>Rotating counter-clockwise</p> <p>Rotating counter-clockwise</p>			

For equipment other than the above, as well as equipment equipped with special motors, ask our company for additional information.

## Connecting fans

For the electrical connection of the fan motor, polymer or ceramic terminal strips are placed in the junction box. When tightening the cable fixing nut, the load capacity of the terminal strip material must be taken into account. Tightening of the nuts is done with appropriate resistance, considering the maximum tightening torque values in the table below.

Screw size	M6	M8	M10
Maximum pulling torque (+0% / -10%)	6 Nm	15 Nm	20 Nm

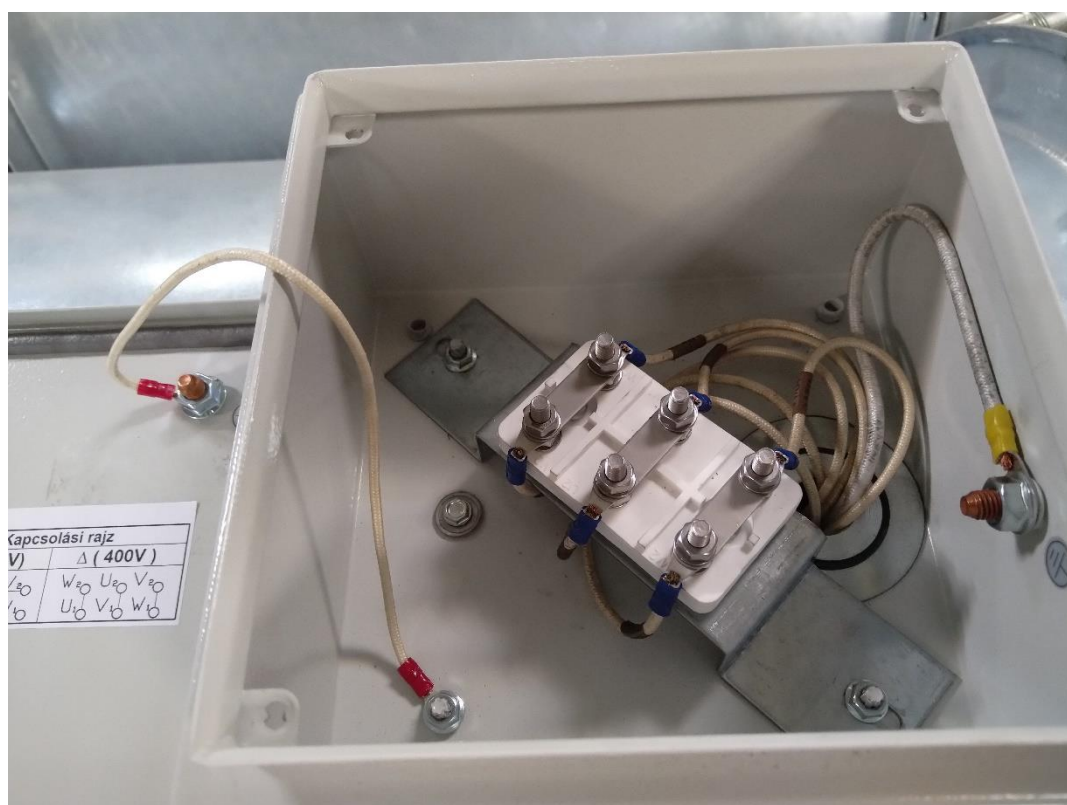

Exceeding the specified torque values can lead to breakage of the terminal strip!  
We are not responsible for damages resulting from improper tightening of the nuts!



## 5.1 - Common installation errors

To reach the desired working point and to guarantee the safe operation of the fan, the following points must be constantly taken care of.

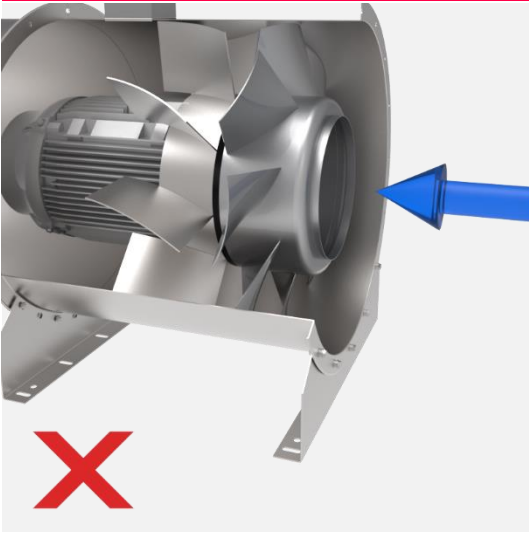
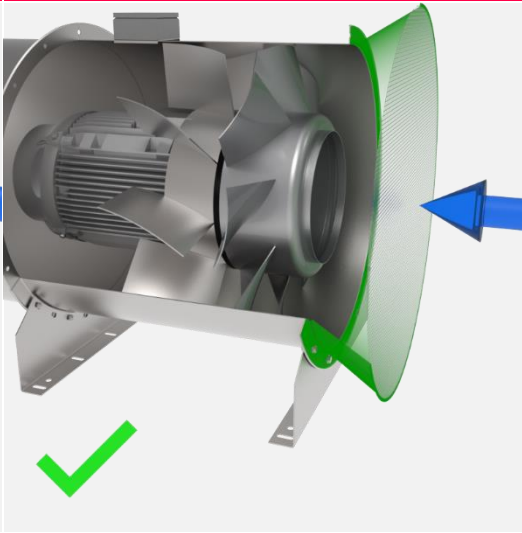
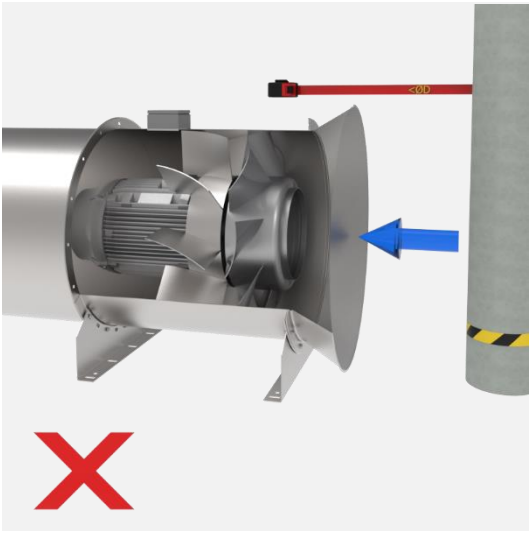
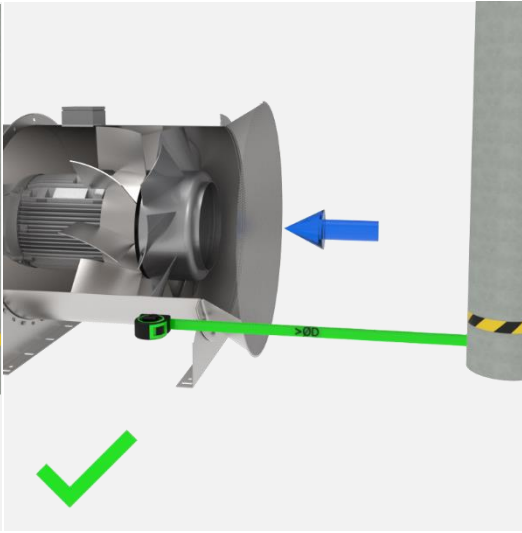
### 5.1.1 - Inflow

INCORRECT	CORRECT
	
<p><b>Incorrect:</b> Without suction nozzles, the ends of the blades are not in the air flow, so the air delivery is reduced, the power consumption and the noise increase. Impeller blades may be damaged. The operating point will not be on the characteristic curve.</p>	<p><b>Correct:</b> In the case of free suction, a suction pipe must be installed in front of the fan.</p>
	
<p><b>Incorrect:</b> There is an obstacle near the inlet side, the performance decreases, the impeller may be damaged.</p>	<p><b>Correct:</b> In the case of free intake, min. before the fan. 1xD free space must be provided.</p>

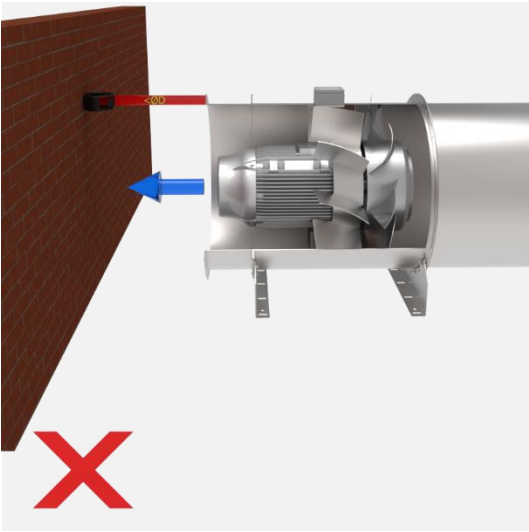
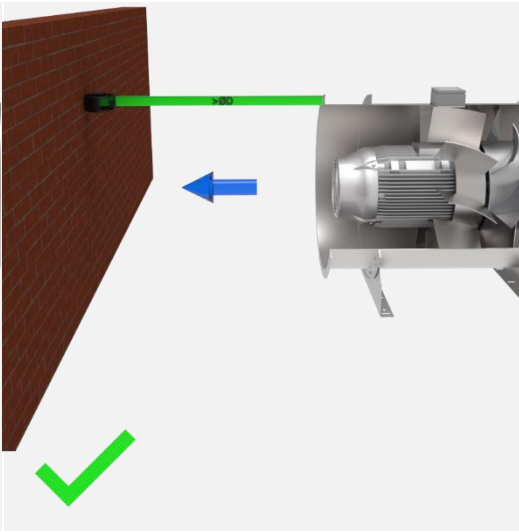
### 5.1.2 - Exhaust

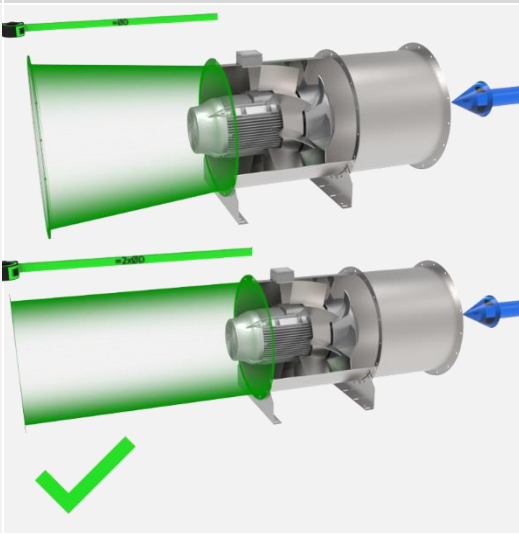
INCORRECT	CORRECT
	
<p><b>Incorrect:</b> An object obstructing the outflow on the pressure side of the fan prevents correct operation.</p>	<p><b>Correct:</b> There should be at least <math>1xD</math> free space on the pressure side of the fan.</p>
	
<p><b>Incorrect:</b> The air duct ends with the fan, the fan blows outside, the exit loss is high!</p>	<p><b>Correct:</b> After the fan, a <math>2xD</math> duct or diffuser reduces exit losses.</p>

5.1.3 – Arches and elbows before and after the fan:

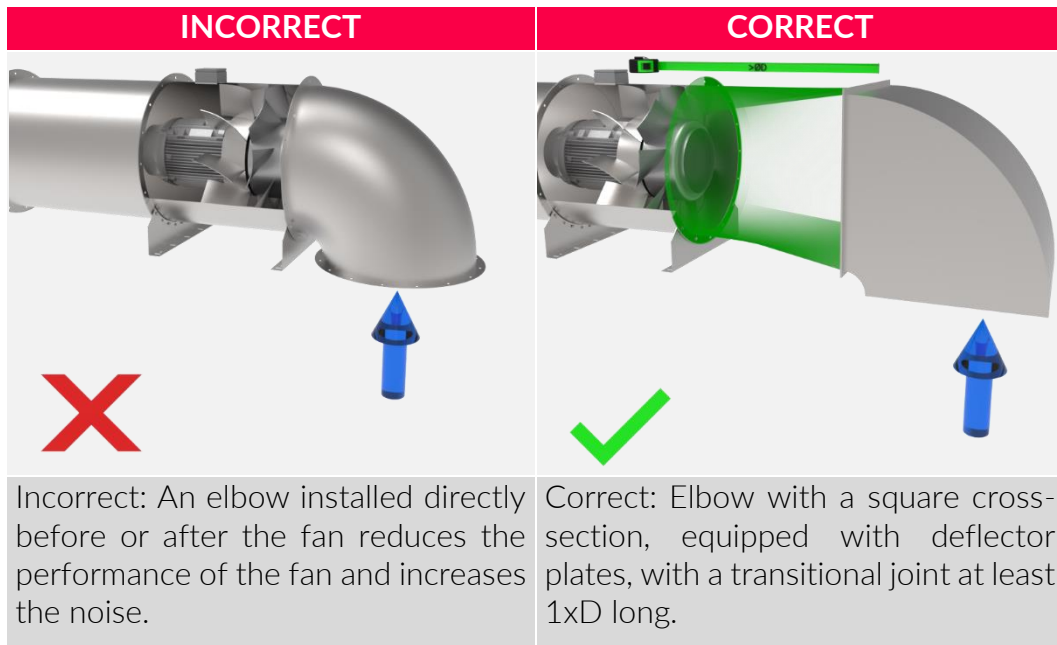

5.1.4 – Cross section changes:

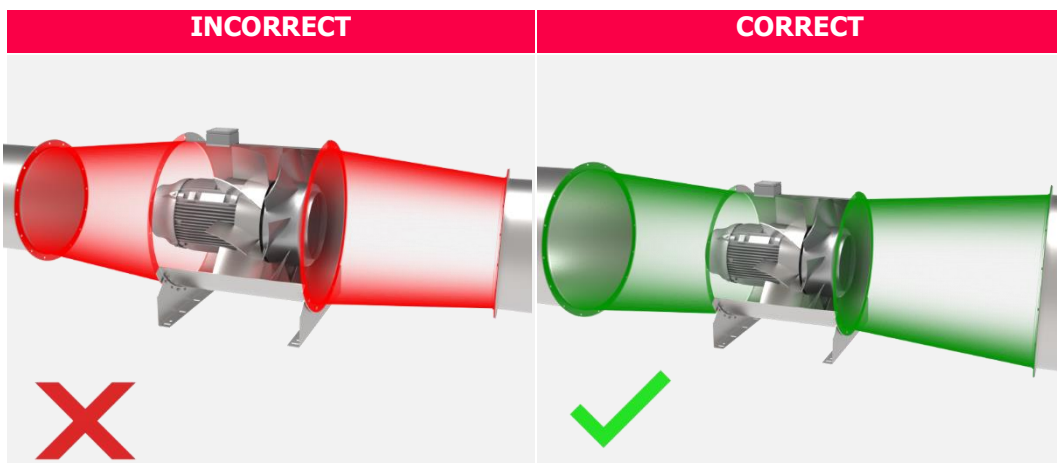

### 5.1.5 – Flexible connections:

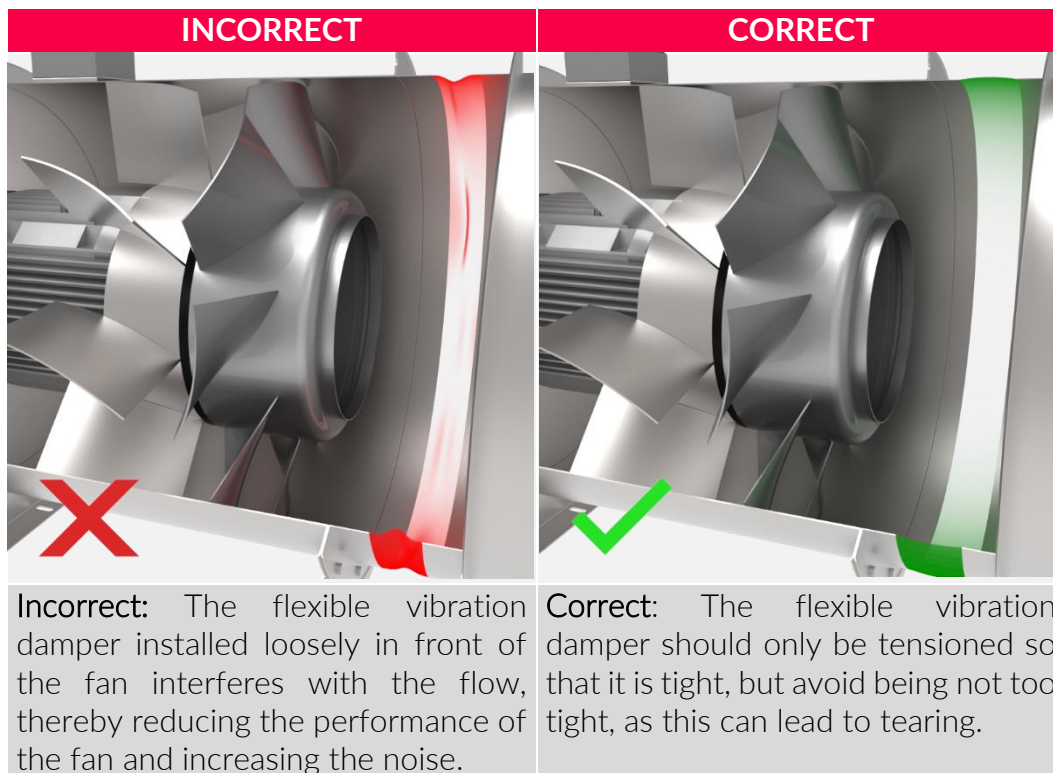



# COMMISSIONING



## To avoid damage to the machine and life-threatening injuries during commissioning, the following points must be observed:

- Commissioning of the machine - in compliance with safety regulations - may only be carried out by qualified personnel.
- Before starting, check that all tools and foreign objects have been removed from the machine.
- Before installation, activate all safety devices and emergency switches.
- Before installation, check the direction of rotation of the motor.
- Read the 'general safety regulation'. chapter. (2.0 points)
- The existence of the commissioning protocol is a condition of the guarantee.

### 6.1 - Check before the first start

#### When installing the fan, proceed in the following order:

- Check for proper installation!
- Remove foreign objects from the suction and discharge side.
- Check that the electrical connection has been made in accordance with the factory wiring diagram and local electrical regulations.
- Is the mains voltage the same as the voltage on the machine's nameplate?
- Is the switch used suitable for the motor in terms of switching functions, switching conditions and switching power?
- Is the motor protection set correctly for the rated current of the motor? The adjustment must be made according to the corresponding values of the motor data plate.
- Is the motor connected correctly according to the wiring diagram? The connection of the motor must basically be carried out based on the motor data plate or on the basis of the circuit diagram attached/sent by the manufacturer.



#### Accident prevention:



- To protect rotating parts from contact, a protective grid (see accessories) must be installed.
- If the fan draws in or pushes to the outside, the suction or pressure opening must be equipped with a protective grid for accident prevention reasons

## 6.2 – Starting the ventilator for the first time



- Only put the fan into operation if it has been installed in accordance with the specifications!
- Check for correct operation (vibration, unbalance, current consumption, etc.).
- If the fan is not operating at the correct (designed) working point (the air delivery is low or the current consumption measured per phase is higher than that stated on the data plate), then ask for the help of a specialist company or the manufacturer. In order to prevent overloading and motor burnout, measure the current consumption, the value of which must not exceed the nominal/maximum current specified on the fan's data plate. If the current consumption of the motor is higher than the value given on the data plate, the overload protection must switch off the motor!
- After a longer period of operation, check the temperature of the bearings. The suction opening must always be kept free and clean! Dirt deposited on the protective grid must be removed!

## 6.3 - Check after the first start

After the first start-up, check the mechanical connections, **especially the fan screws**.



## OPERATION

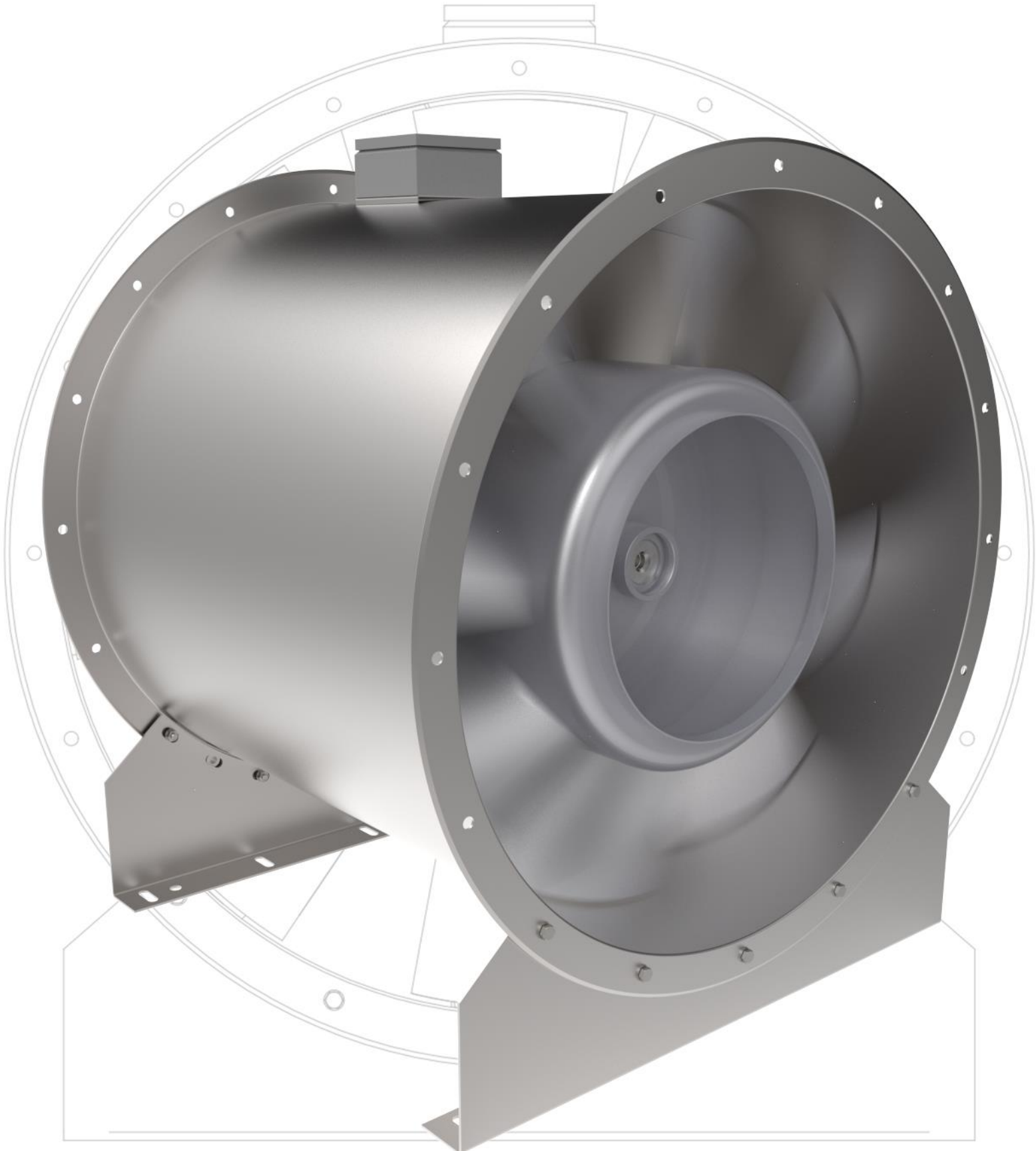

During the operation of the machine, to prevent life-threatening injury to the operator and damage to the machine, the following safety advice must be observed.

Cleaning and maintenance work - in strict compliance with the operating instructions - may only be carried out by qualified personnel.

- Repair work may also only be carried out by specialist personnel - in compliance with accident prevention regulations.
- Before carrying out cleaning, repair, maintenance and other installation work, the fan must be completely disconnected from the electrical network, with a reconnection prohibition (padlock, lock, etc.) at the same time.
- Secure the area before starting operational work.
- The specified sequence of work must be followed.
- Only qualified electricians may work on electrical equipment.
- The specified tightening torque of the screws must be observed.
- Read the "general safety regulations". chapter. (2.0 points)

### Electrical operating conditions:

- 1) In the case of starting a motorized closing damper and a fan together, the damper must be opened in the first step. The fan should be started with an open damper, optimally with a delay of **20 seconds** - but at least **10 seconds**.
- 2) Hungaro-Ventilátor Kft.'s smoke extraction fans are certified for fire operation in accordance with the Local Fire Regulation according to the EN 12101-3 standard together with the **DANFOSS FC 102** series frequency converter. By using a frequency converter, you can save a significant amount of expensive automation elements.
- 3) The smaller STAR motor - usually under 3 kW - marked **"Y"** on the data sheet - **230/400 V (50 Hz)** - starts directly, i.e. **DOL (Direct On Line)** - its current can be found on the data sheet.
- 4) The DELTA motor with a higher power - usually above 3 kW, marked **"D"** on the data sheet - **400/690 V (50Hz)** - is usually started with star/delta (**Y/Δ**) switching in the case of a 3x400V supply voltage. In this case, the short-term current maximum is approx. the rated current of the motor. **3** times. If there is sufficient available current, direct, i.e. **DOL (Direct On Line)** starting is also possible. Its current can be found on the data sheet.
- 5) In the case of starting with a soft starter or a frequency converter, the starting current does not exceed the rated current of the motor.
- 6) **In case of fire operation, the motor protection must be disabled**, the fan cannot stop in case of overcurrent or overheating. In the case of a trial run or function test, the guarantee condition is that the motor protection is active!
- 7) In a non-fire function, the fan motor must be protected against overheating with PTC motor protection and against overcurrent with overcurrent protection. To protect the fans from overcurrent, a small circuit breaker with characteristic **"D"** or a fuse of category **"aM"** must be used! If a fuse is used, a **phase monitoring relay** must be apply to prevent phase loss. Malfunctions resulting from the lack of motor protection are not covered by the warranty.

**Contact:**

Phone: +36 99 536 072 / Fax: +36 99 536 073 / E-mail: [sales@hungaro-ventilator.hu](mailto:sales@hungaro-ventilator.hu)



# TROUBLESHOOTING

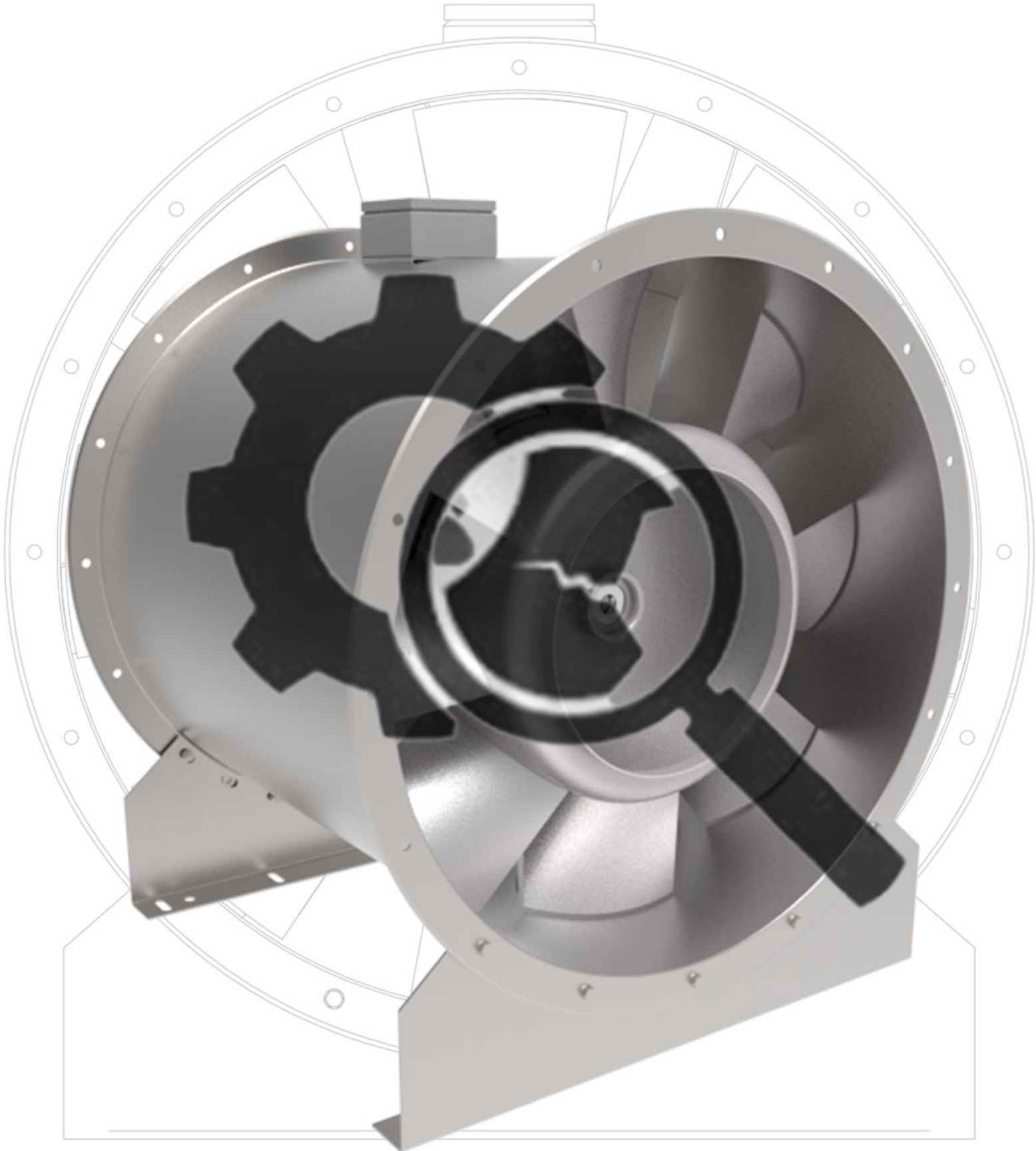

**When troubleshooting, pay particular attention to the following points:**

- The fault can only be eliminated by a person with appropriate professional qualifications.
- First, the machine must be secured against unintentional restart (accidental) by turning the machine's switch or closes its switch cabinet.
- Secure moving parts against rotation.
- Read the “general safety regulation” chapter. see (2.0. point)

**7.1 - Tabular overview of possible disturbances and help for troubleshooting**

Failure	Cause	Troubleshooting
The motor or motor control switches off	The motor has overheated, the thermal contact trips.	Cool down the engine. Depending on the switch, the fan restarts itself or needs to be restarted. Check that: <ul style="list-style-type: none"> <li>• Is the delivered medium too hot?</li> <li>• Are all phases equally loaded and connected?</li> <li>• Does the fan’s operation point match the selection?</li> <li>• Is the impeller jammed/stuck?</li> </ul>
	The impeller is blocked.	Turn off the fan. Remove the obstruction. In the meantime, pay attention to the safety regulations.
	The impeller is damaged and worn.	Turn off the fan. Remove the impeller and install a new one.
	Filter or roof cap perforation is dirty	Replace or clean the filter.
	The back draft damper was installed in the reverse position.	Reverse the installation direction of the back draft damper.
The fan pumps, the air flow is interrupted periodically.	The fan works in the unfavorable characteristic curve area	Check the correct installation of the non-return valve. In case of incorrect (inverted) installation, turn it over. Reduce system resistance if possible. In case of continuous operation, the impeller of the fan will be destroyed.
Inadequate air flow	The slats of the automatic sunroof are dirty and do not open.	Turn off the fan. Carry out the necessary cleaning or repair.



# MAINTENANCE

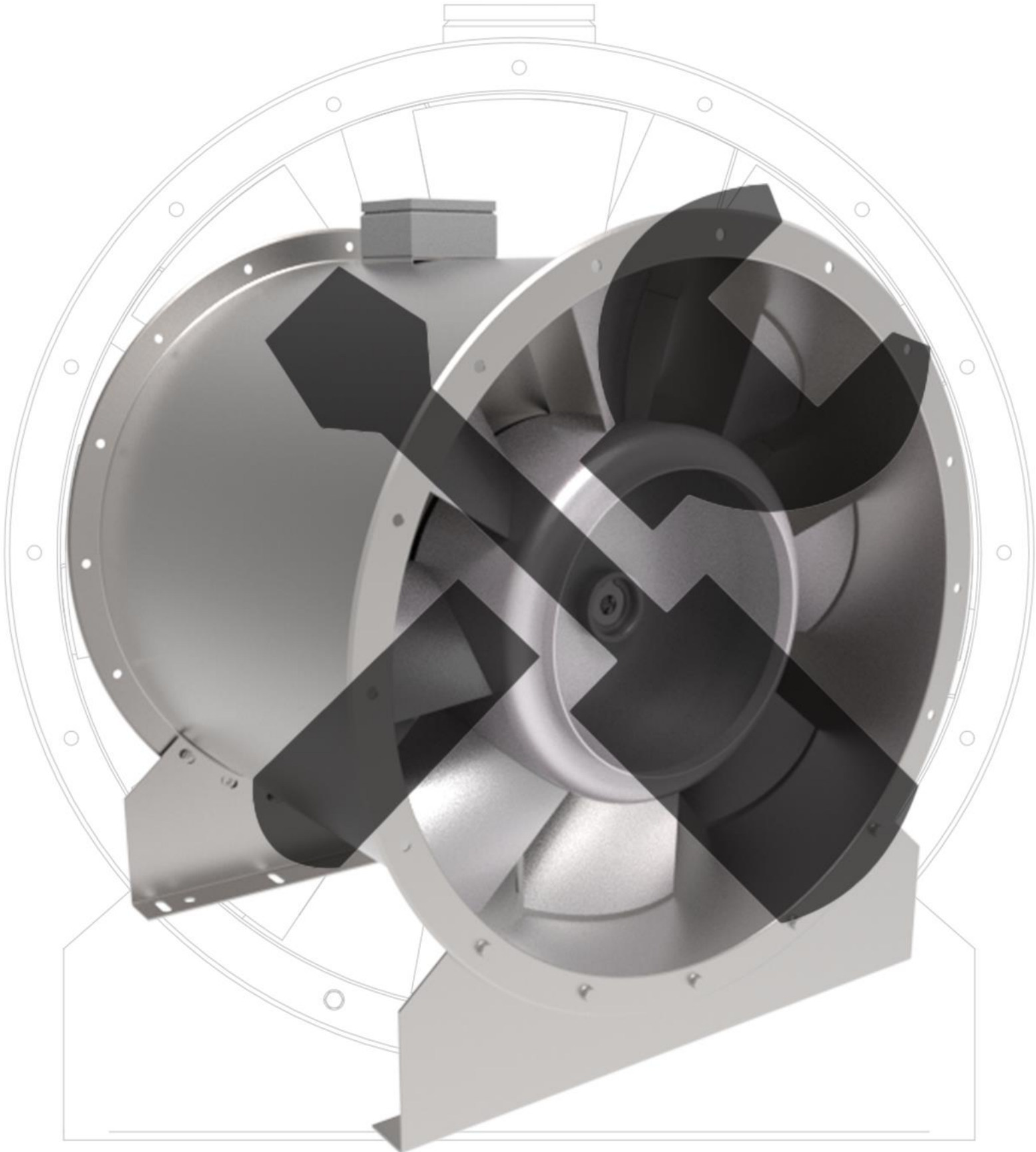

## Professional maintenance is a condition of the warranty!

### Factory Service:

Hungaro-Ventilator Kft. (H-9483 Sopronkövesd, Táncsics M. u 18.)

E-mail: [service@hungaro-ventilator.hu](mailto:service@hungaro-ventilator.hu)

Tel.: +36-99-536-072

### Maintenance intervals:

For normal air ventilation fans, **3 months is recommended** (depending on air pollution).

### CAUTION!

Please carry out the maintenance work in this guide at the specified intervals - failure to do so will void the warranty. It also voids the warranty and endangers the safety of operation if you do not use spare parts distributed by the manufacturer!

Dust, caustic and acidic vapors and gases mixed with the transported air flow have a natural abrasive and corrosive effect on the impeller and the housing and can deposit. Because of these natural wear and tear, the material can wear out to such an extent that it no longer meets expectations. Uneven deposits on the impeller can cause imbalance and thus unstable running, which in turn leads to damage to the motor bearings. Deposits on the housing lead to a reduction of the free cross-section and a roughening of the housing, which adversely affects the performance data of the fan. If the inspection, which depends on the transported medium and the different operating conditions in each case, shows even a small amount of wear, then the individual parts must be cleaned in time, in case of greater wear, immediate replacement is justified.

### Before any kind of maintenance work:

- The fan must be properly stopped and completely disconnected from the electrical network, simultaneously with a reconnection prohibition (padlock, lock, etc.).
- Wait until the impeller stop!
- Ensure non-restartability!
- Clean the fan.
- Clean the suction opening.
- Clean the impellers (if necessary, remove the protection against penetration).



In addition to following the prescribed safety instructions, only use commercially available cleaning agents! The use of scratching or rubbing tools that damage the surface protection is prohibited!

- Protect the engine from water jets!
- The integrity of the impeller and blades must be checked!



## General checks:

- Is lubricant leaking from the bearing?
- Is the surface protection intact? (Caution: Aggressive transported medium?)
- Unusual operating noises

**Important:** The screws of the fan (except for the screws of the electrical connection. see: Installation) and the screws for fixing the impeller must be tightened with the torque specified in the attached tables!

## Screws (strength class 8.8):

Screws	M4	M5	M6	M8	M10	M12	M14	M16	M18	M20
pulling torque (+0% / -10%)	3,4 Nm	6,5 Nm	11 Nm	28 Nm	55 Nm	95 Nm	155 Nm	230 Nm	275 Nm	385 Nm

**The given values refer to galvanized screws and non-oiled screw joints!**

**Engine Bearings check:** Using bearing diagnostic tools

**CAUTION:** The electric motor can only be dismantled by the manufacturer or a specialist company designated by the manufacturer!

In the event of a limited motor fault, notify the manufacturer or distributor of the fan! De-energize the fan motor at the same time as reporting the error, but do not disconnect the wiring, leave it unchanged.

**By disassembling the engine, the operator assumes all legal consequences!**

## Steps of Commission:

- Commissioning of the machine - in compliance with safety regulations - may only be carried out by qualified personnel.
- Before starting, check that all tools and foreign objects have been removed from the machine.
- Reinstall protection against intrusion
- Before installation, activate all safety devices and emergency switches.
- Before installation, check the direction of rotation of the motor.
- Read carefully the "General safety regulations". chapter. (2.0 points)

## Thank you for your attention!

We trust that the above instructions will help and support you in your work and that the equipment will operate as intended.



## They chose us:

- ✓ Elysium Residential Park
- ✓ M4 Metro Budapest
- ✓ Széchenyi Bath
- ✓ Groupama Arena
- ✓ Puskás Stadium
- ✓ Museum of Fine Arts
- ✓ Hungarian Academy of Sciences

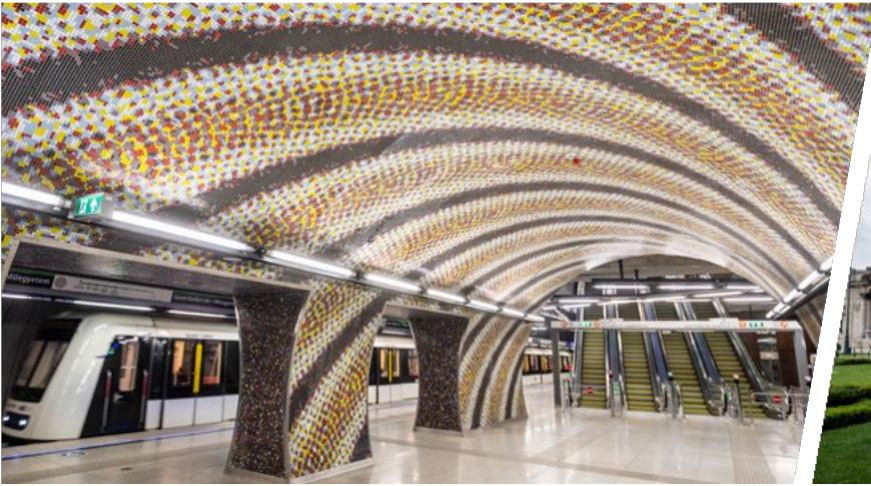

## Why choose us?

- ✓ We believe in the power of quality: due to the reliability of our products, the number of complaints is minimal
- ✓ Adherence to the delivery deadline is a basic requirement for the company
- ✓ Our products have outstanding price
- ✓ In addition to design and installation expertise, we also have the appropriate manufacturing tools
- ✓ Our products meet all comfort and technological, air-conditioning requirements, as well as modern, energy-saving and aesthetic
- ✓ The product innovation is continuous
- ✓ Thanks to the large stock, we can ensure a short delivery time
- ✓ Our excellent and recognized professionals are available to our clients
- ✓ All equipment's accessories are self-manufactured
- ✓ Our unique VentiCalc fan selection software for our business partners is connected to the main manufacture software, so there is no unnecessary lead time, thus the production time is shortened



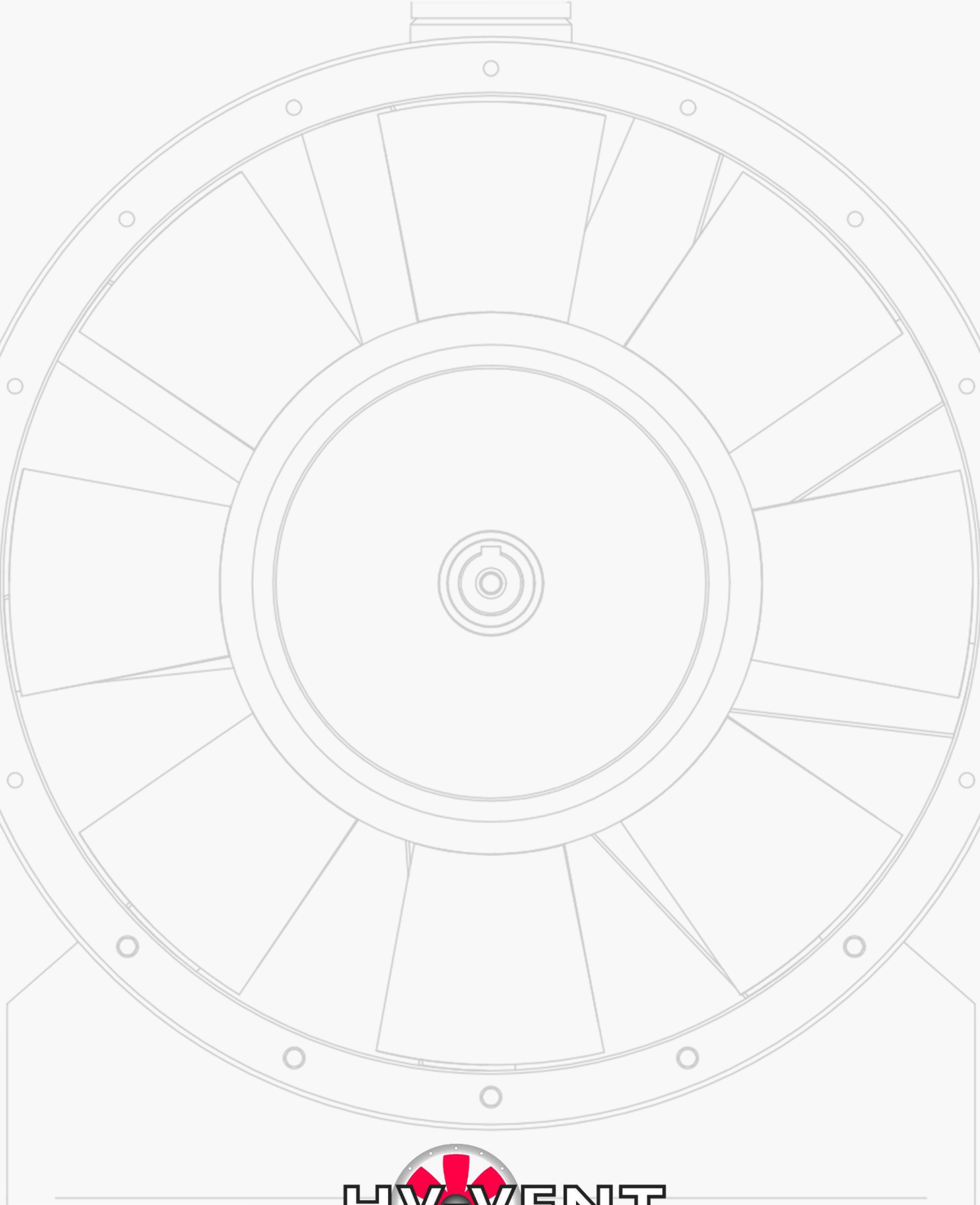

[www.hungaro-ventilator.hu](http://www.hungaro-ventilator.hu)